

Volume 6711 AC

Nov 67

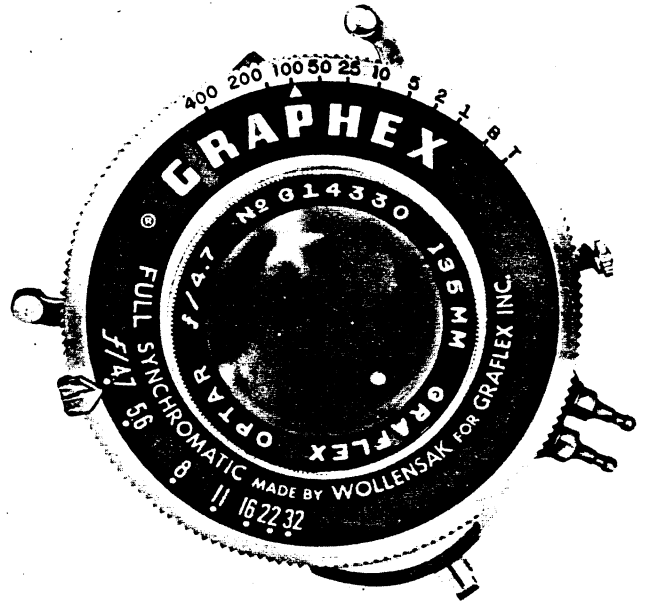
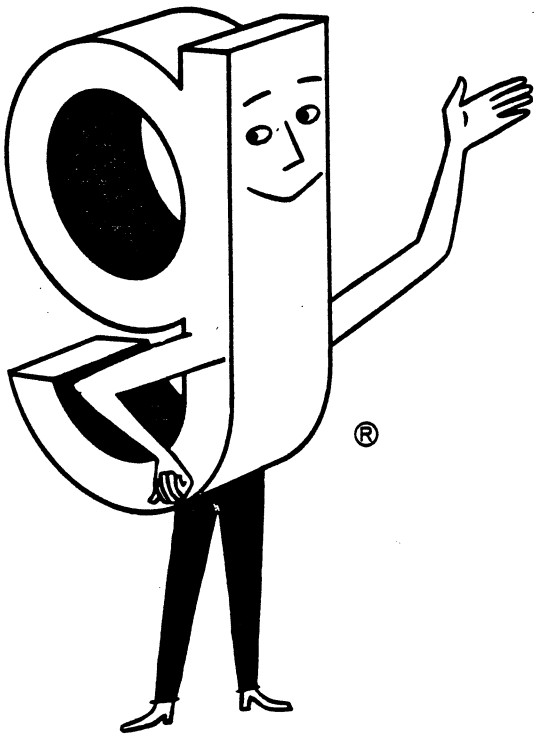

graflex®

PHOTOGRAPHIC EQUIPMENT SERVICE INSTRUCTIONS AND PARTS LIST

GRAPHLEX SHUTTERS

(Sizes: No. 1, 2, and 3)

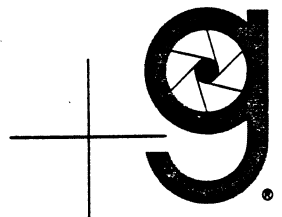

GRAFLEX REGIONAL SERVICE CENTERS

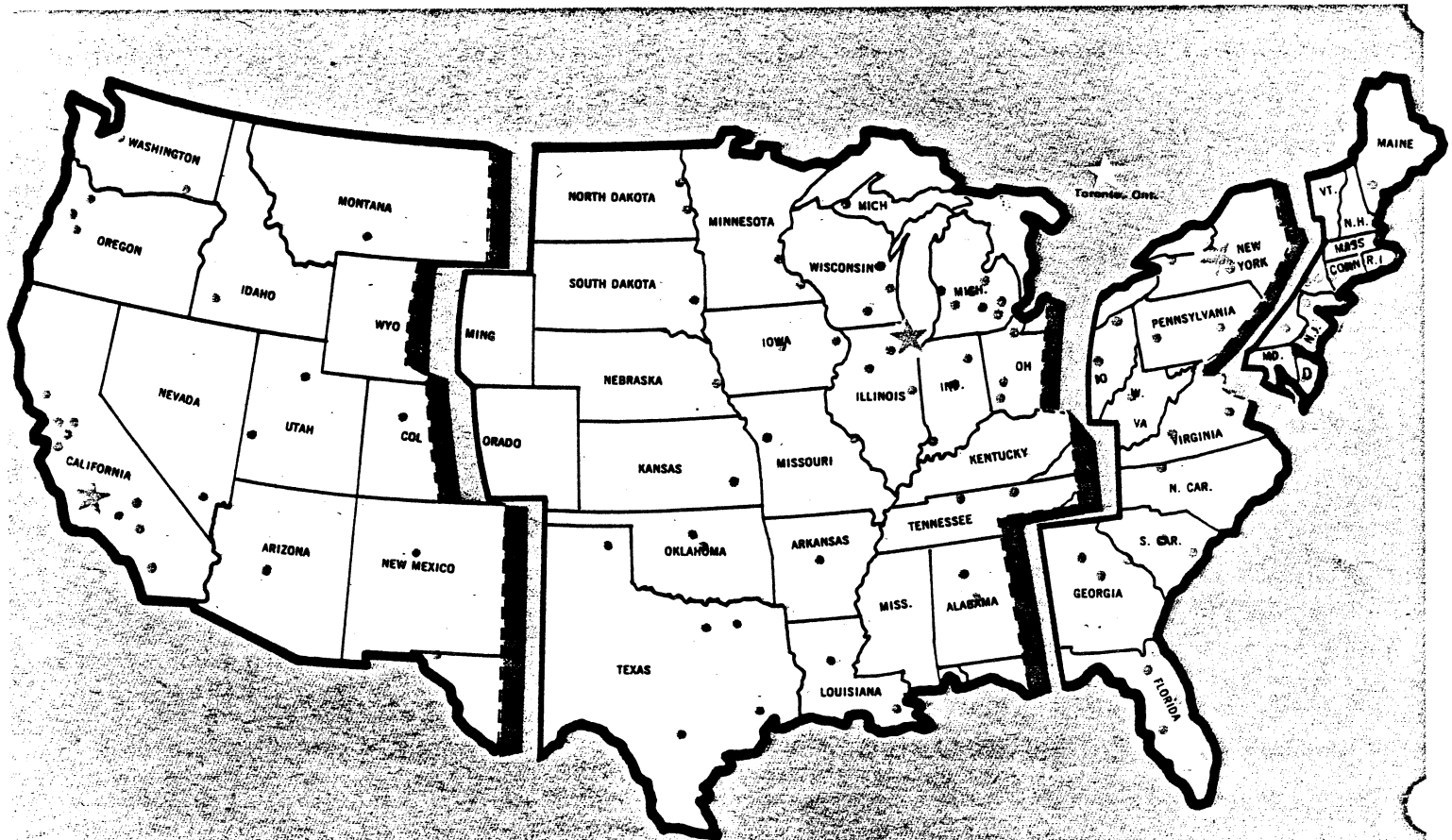

ROCHESTER, N. Y.
Graflex, Inc.
3750 Monroe Ave.
Rochester, N. Y. 14603
Tel: 716-586-2020 or
716-865-3000

NEW YORK CITY AREA
Graflex, Inc.
411 Sette Drive
Paramus, New Jersey 07652
Tel: 201-261-3358

CHICAGO, ILL.
Graflex, Inc.
5515 N. Milton Parkway
Rosemont (Chicago), Illinois 60018
Phone 312-671-1320

HOLLYWOOD, CALIF.
Graflex, Inc.
800 North Cole Ave.
P.O. Box 38606
Hollywood, Calif. 90038
Tel: 213-463-8195

IN CANADA
Graflex of Canada, Ltd.
47 Simcoe Street
Toronto, Ontario
Tel: 416-366-9681

GRAPHEX SHUTTER

TABLE OF CONTENTS

Section	Title	Para.	Page
I	Theory of Lens and Shutter		1
	General Information	1	1
	Shutter Speed Settings	2	1
	Shutter Cocking	3	1
	Shutter Tripping	4	1
	Press Focus Operation	5	3
	Time Setting	6	3
	Bulb Setting	7	4
	Diaphragm Setting	8	4
	Cable Release Mechanism	9	6
Synchronizer Operation	10	6	
II	Troubleshooting		6
	General Information		6
III	Lens and Shutter Assembly		
	Repair and Alignment		11
	Parts Replacement	11	11
	Repairs - General	12	25
	No. 1 Shutter, Disassembly	13-18	25-26
	No. 2 and 3 Shutter, Disassembly	19-24	26-27
	Cleaning Disassembled Parts	25	27
	Lubrication	26	27
	No. 1 Shutter, Reassembly	27-32	27-30
	No. 2 and 3 Shutter, Reassembly	33-38	31-34
Adjusting Shutter Speeds	39	34	
IV	Final Testing		35
	General Information	40	35
	Physical Testing of Lens and Shutter Assemblies	41	35
	Shutter Speed Test	42	35
	"M" Synchronizer Delay Test	43	36
	"X" Synchronizer Delay Test	44	36
	Operational Ranges of Shutter Speed Settings	45	37
	Operational Ranges of Synchronizer Delay Settings	46	37

LIST OF ILLUSTRATIONS

Figure 1	Slow Shutter Speeds	2
Figure 2	Fast Shutter Speeds	2
Figure 3	Cocking and Tripping Mechanism	3
Figure 4	Blade Closing Mechanism	4
Figure 5	Time and Bulb Lever Operations	5
Figure 6	Diaphragm Operation	5
Figure 7	Synchronizer Operation	6
Figure 8-13	No. 1 Shutter, Disassembly - Stage 1 - 6	11-16
Figure 14-19	No. 2 and 3 Shutter, Disassembly - Stage 1 - 6	17-22
Figure 20	No. 1 Shutter, Spring Positions	23
Figure 21	No. 2 and 3 Shutter, Spring Positions	24
Figure 22	No. 1, 2, and 3 Shutter, Main Lever Alignment	30
Figure 23	Berkley Time and Interval Meter	38
Figure 24	"X" Synchronizer Delay Tester	38

INTRODUCTION

This Manual has been prepared as a guide for service and maintenance of the No. 1, No. 2 and No. 3 Graphex Shutter. Obvious procedures are not stated. The text will clearly describe the differences.

Section I. THEORY OF LENS AND SHUTTER

1. General Information

The three between-the-lens shutters No. 1, No. 2 and No. 3 Shutters are similar in design; consequently the theory of their operation is combined in paragraphs 1 through 10. Explanation of differences will be noted by an underlined description of the shutter concerned. This section is divided into the following nine paragraphs: shutter speed settings, shutter cocking, shutter tripping, time setting, bulb setting, press focus operation, diaphragm setting, cable release mechanism, and synchronizer operation. Each paragraph defines the interrelationship of shutter parts which are concerned with the proper functioning of the mechanisms listed in the heading of that paragraph. Figures 1 through 7 are used to aid in identifying parts described in text.

2. Shutter Speed Settings (fig. 1 and 2)

a. Speed Cam Assembly. As each shutter speed engraved on the speed cam assembly is set to the fiducial mark on the nameplate, two cam slots in the speed cam assembly position the retarding lever assembly, the pallet lever assembly stud, and the retarding weight assembly to achieve the indicated shutter speed.

NOTE

No. 1 Shutter has no retarding weight.

b. Gear Train. The gear train consists of the retarding wheel, the center wheel, the escapement wheel and the retarding lever assembly. The gear train operates as the retarding lever assembly pivots.

NOTE

No. 1 Shutter has no center wheel.

c. Retarding Lever Assembly. The retarding lever assembly retards the main lever assembly when the shutter is tripped except when the shutters are set at the following speeds indicated:

- (1) No. 1 Shutter, speed setting 400.
- (2) No. 2 Shutter, speed setting 400.
- (3) No. 3 Shutter, speed setting 200.

d. Pallet. At speed settings 1, 2, 5, and 10 the speed cam positions the pallet near the escapement wheel of the gear train, and the back and forth rotation of the pallet offers additional retardation to the gear train. At speed settings 10, 25, 50, and 100 the pallet is disengaged from the escapement wheel.

e. Retarding Weight

- (1) No. 1 Shutter has no retarding weight.
- (2) No. 2 Shutter. At speed settings 200 and 100 the speed cam positions the retarding weight to retard the pivoting of the main lever. Since positioning allows longer travel of the retarding weight at a speed setting of 100, greater retardation is given to the main lever assembly than with the speed setting at 200.
- (3) No. 3 Shutter. The retarding weight is positioned to retard the main lever only at speed setting of 100.

f. High Speed Spring

- (1) No. 1 Shutter. The high speed spring is tensioned when the shutter is cocked and assists in rotating the main lever when the shutter is released at all speed settings.
- (2) No. 2 Shutter. When the speed cam is rotated to the 400 speed setting, the high speed spring is tensioned by the stud on the speed cam and boosts the pivoting of the main lever.
- (3) No. 3 Shutter. When the speed cam is rotated to the 200 speed setting, the high speed spring is tensioned by the stud on the speed cam and boosts the pivoting of the main lever.

3. Shutter Cocking (fig. 3)

a. Cocking Lever, Main Lever, and Release Lever.

Moving the cocking lever to its farthest clockwise position pivots the main lever assembly clockwise to engage with the release lever.

b. Main Lever Spring and Auxiliary Spring. When the shutter is cocked these springs are tensioned, applying a counterclockwise force on the main lever.

NOTE

No. 1 Shutter. The high speed spring functions as an auxiliary spring.

4. Shutter Tripping (fig. 3 and 4)

a. Release Lever. When the shutter is cocked, pressing the release lever counterclockwise frees the main lever.

b. Blade Lever. When the shutter is tripped the counterclockwise pivoting of the main lever pivots the blade lever counterclockwise.

GRAPHEX SHUTTERS

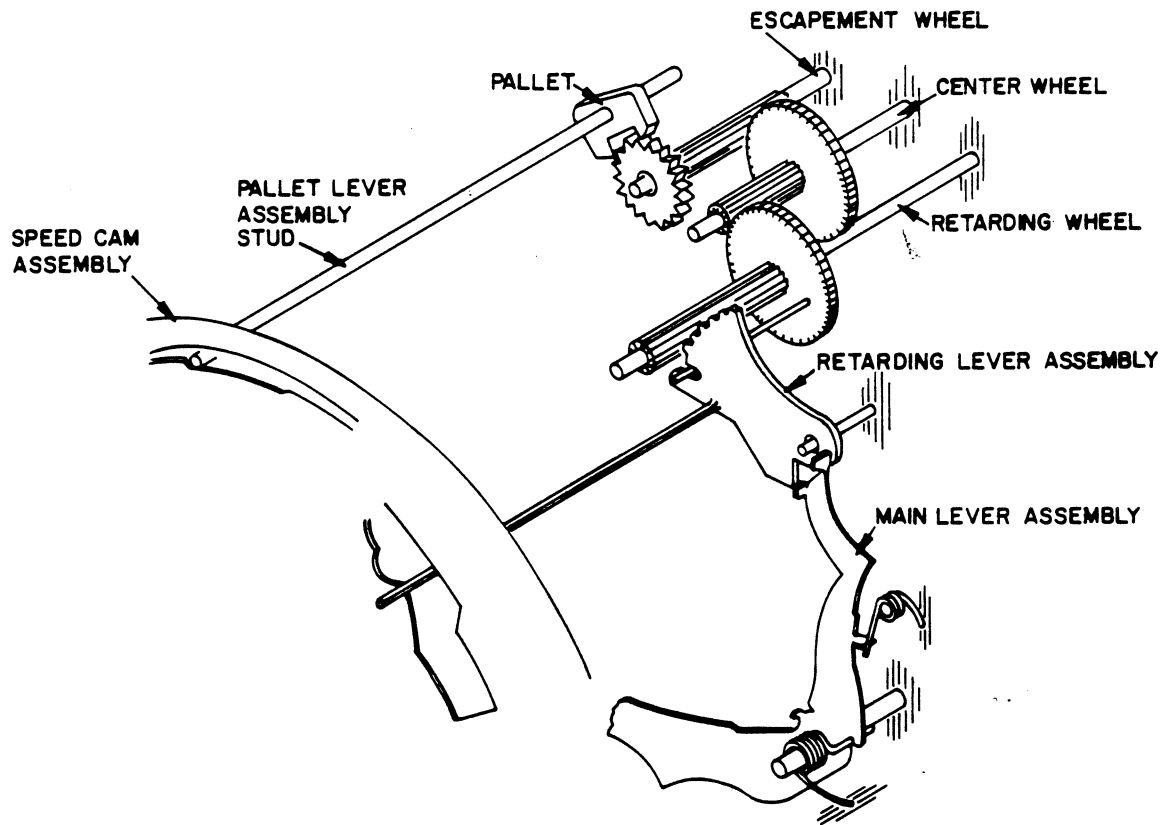

Figure 1. SLOW SHUTTER SPEEDS

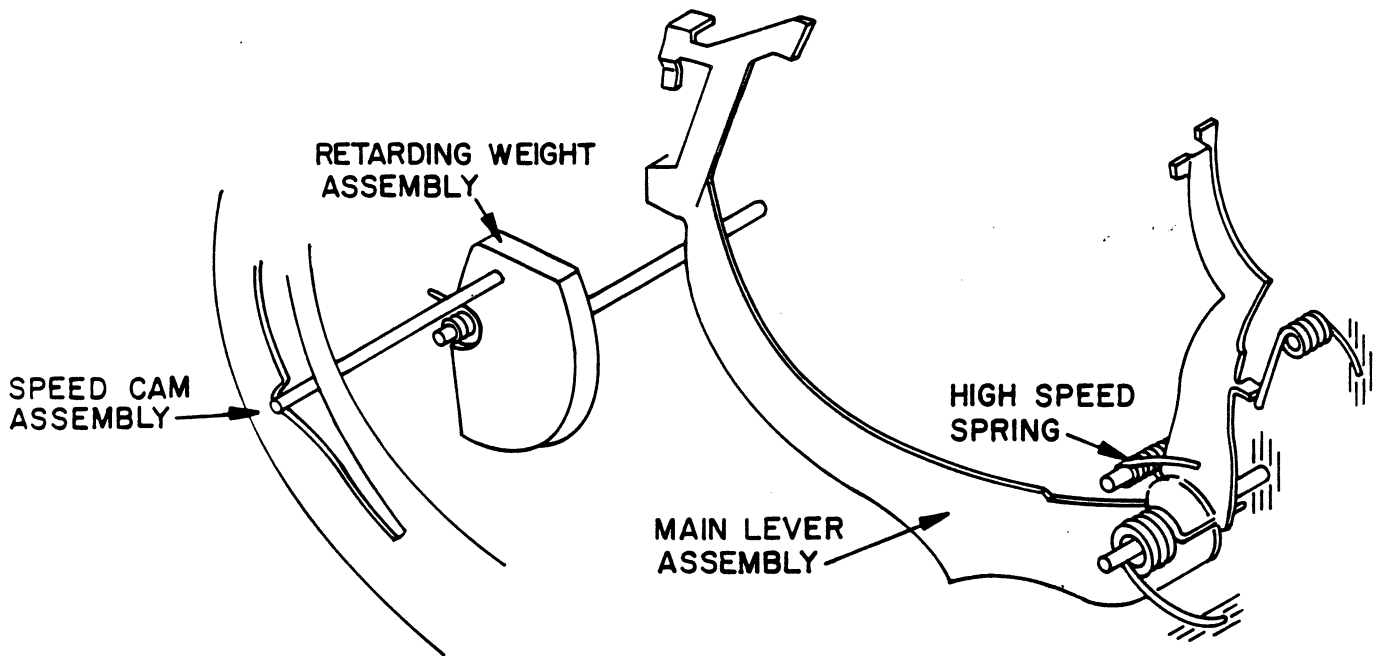

Figure 2. FAST SHUTTER SPEEDS

GRAPHEX SHUTTER

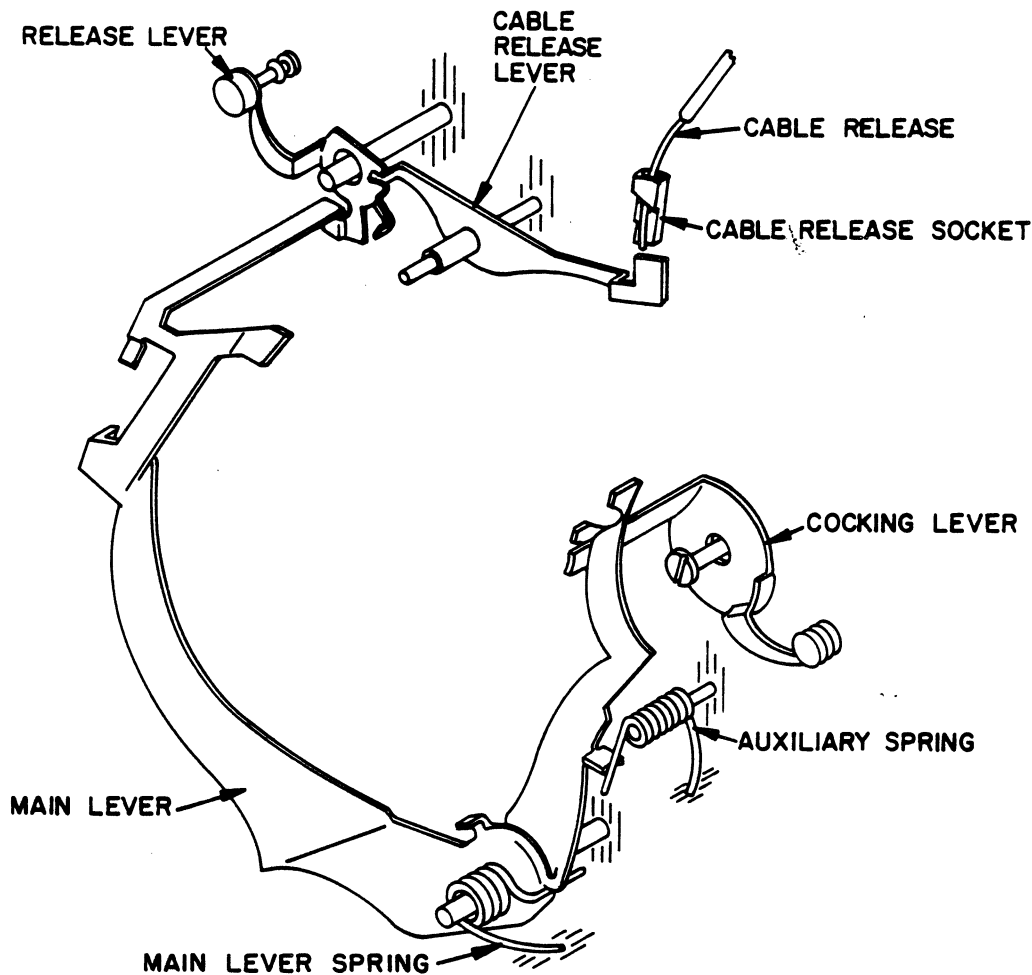

Figure 3. COCKING AND TRIPPING MECHANISM

c. Revolving Ring Assembly. As the blade lever is pivoted by the movement of the main lever it, in turn, pivots the revolving ring assembly clockwise and opens the shutter blades. Further travel of the main lever pivots the revolving ring assembly clockwise and closes the shutter blades.

d. Shutter Blades. A stud, which fits into a hole on the diaphragm plate and leaf assembly, is located on each shutter blade. Each shutter blade also has a hole which fits over a corresponding post on the revolving ring assembly. When the revolving ring is pivoted clockwise the movement of the ring is transferred to the shutter blade which pivots and moves to the open position. Counterclockwise movement of the revolving ring assembly reverses the procedure and closes the blade.

5. Press Focus Operation (fig. 4)

a. Focus lever. With the shutter cocked, pressing the focus lever pivots the revolving ring assembly clockwise. Returning the focus lever to its original position pivots the revolving ring counterclockwise.

b. Revolving Ring Assembly. When the revolving

ring assembly is pivoted the action is the same as in paragraph 4.c. except that the revolving ring is pivoted by the sliding movement of the focus lever.

c. Shutter Blades. When the press focus is operated the shutter blade action is the same as described in paragraph 4.d.

d. Main Lever

- (1) No. 1 and 2 Shutters. When the shutter is not cocked a lug on the focus lever bears on the main lever and prevents movement of the focus lever.
- (2) No. 3 Shutter. The lug on the focus lever engages with the stop lever which prevents movement of the focus lever when the shutter is not cocked.

6. Time Setting (fig. 5)

a. Speed Cam Assembly. Positioning the speed cam to the "T" setting moves the cam notch to a position which allows the bulb and time levers to pivot when the shutter is tripped.

GRAPHEX SHUTTERS

b. Bulb Lever. When the release lever is tripped and held the bulb lever pivots and positions so that it engages the main lever when the shutter blades are fully open.

c. Time Lever. When the release lever is allowed to return to its rest position the bulb lever also pivots to its rest position; however, the time lever pivots and positions so that the main lever remains captured and the shutter blades stay fully open.

b. Bulb Lever. When the release lever is tripped and held the bulb lever pivots and positions so that it engages the main lever when the blades are fully open.

c. Release Lever. When the release lever is tripped and held, the bulb lever will keep the main lever positioned with the shutter blades fully open. When pressure is removed from the release lever, the bulb lever is pivoted and allows the main lever to continue its travel and close the shutter blades.

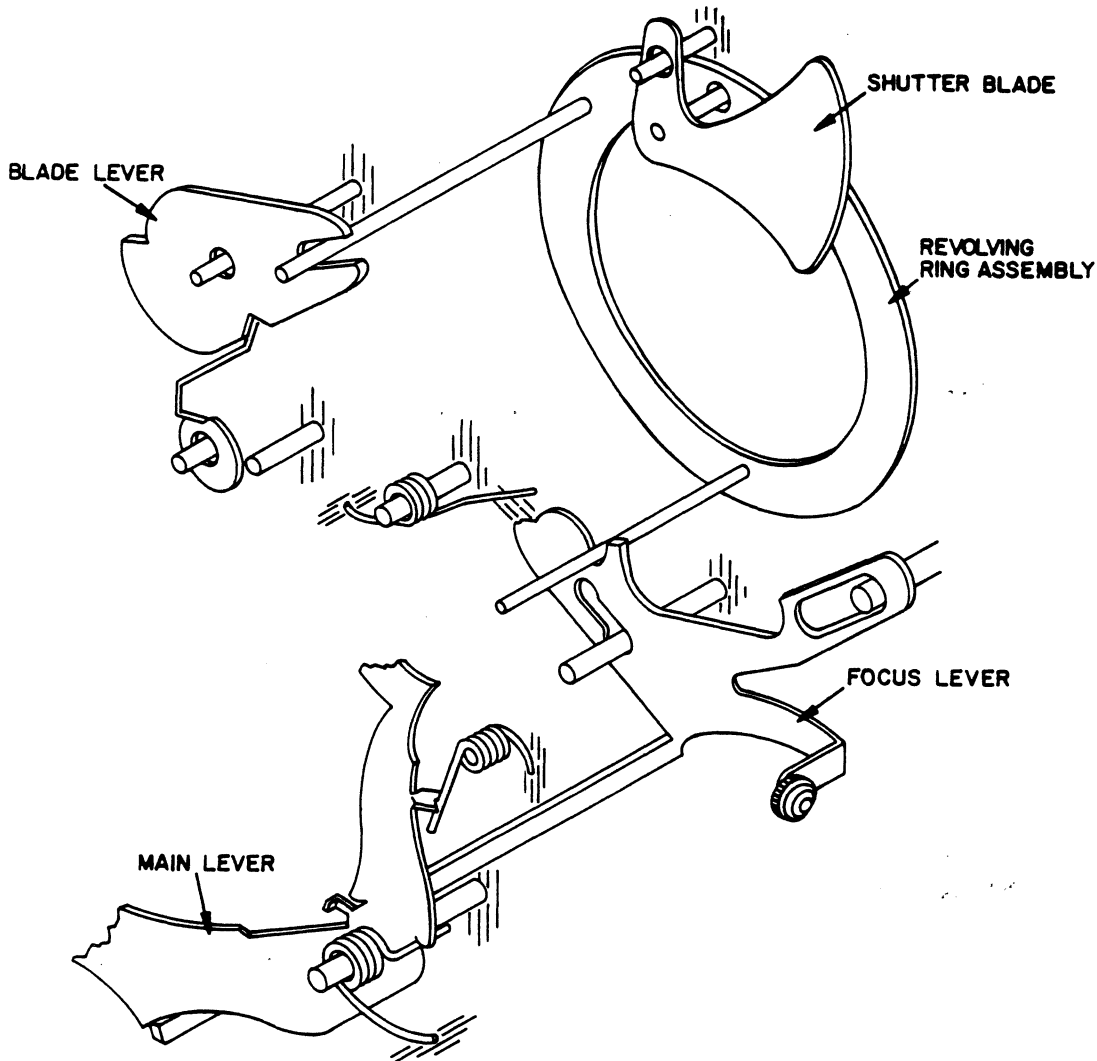

Figure 4. BLADE CLOSING MECHANISM

d. Release Lever. When the release lever is tripped and released it acts on the bulb and time levers as described in sub-paragraphs "b" and "c" above. When the release lever is retripped the time lever is pivoted and allows the main lever to continue its travel and close the shutter blades.

7. Bulb Setting (fig. 5)

a. Speed Cam Assembly. Positioning the speed cam assembly to the "B" setting moves the cam notch to a position which allows pivoting of the bulb lever but not the time lever.

8. Diaphragm Setting (fig. 6)

a. Diaphragm Indicator Ring. By its position the diaphragm indicator ring pointer denotes the f stop setting of the shutter. Slots in the diaphragm indicator ring engage one end of each diaphragm leaf, and movement of the ring simultaneously repositions each leaf to give a larger or smaller f stop opening.

b. Diaphragm Plate and Leaf Assembly. One end of each diaphragm leaf is staked to the diaphragm plate and leaf assembly and pivots as the diaphragm indicator ring is pivoted.

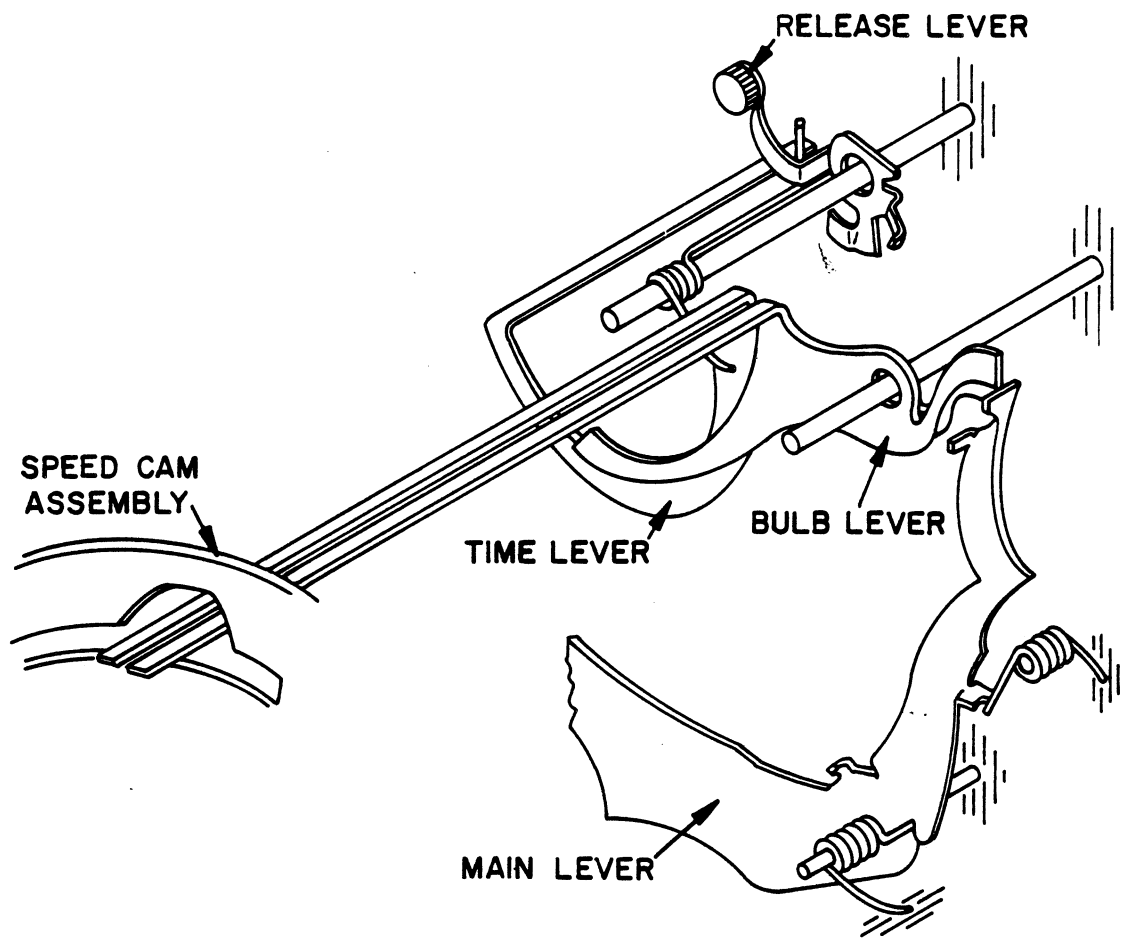

Figure 5. TIME AND BULB LEVER OPERATION

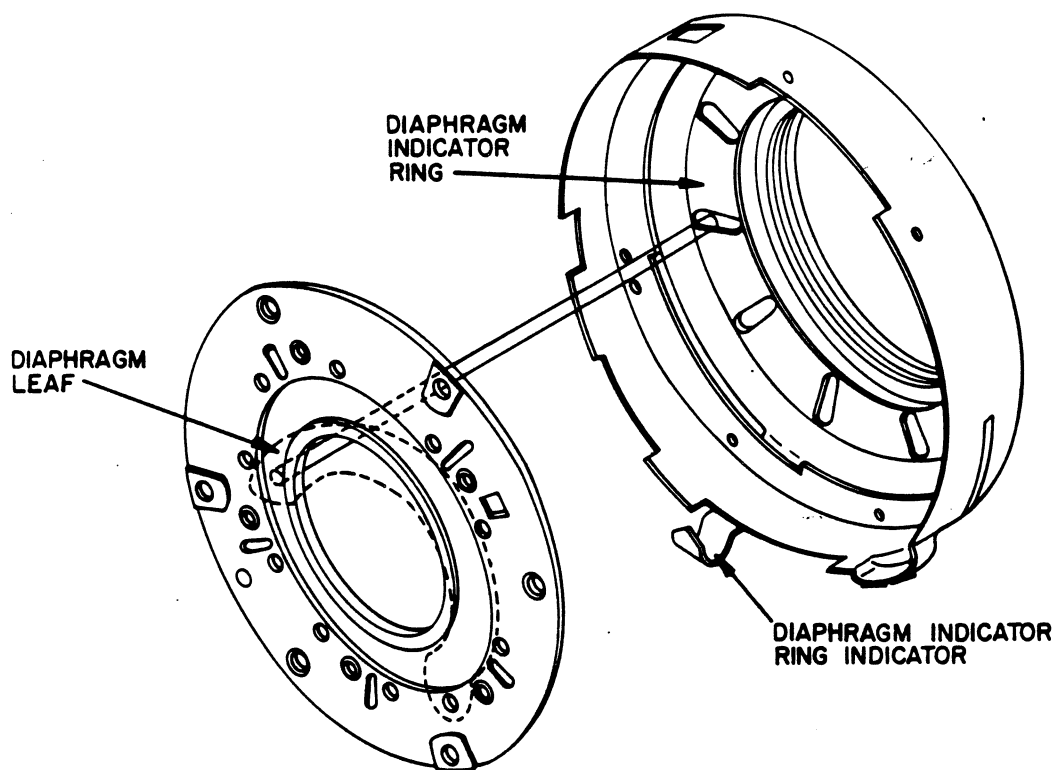

Figure 6. DIAPHRAGM OPERATION

GRAPHEX SHUTTERS

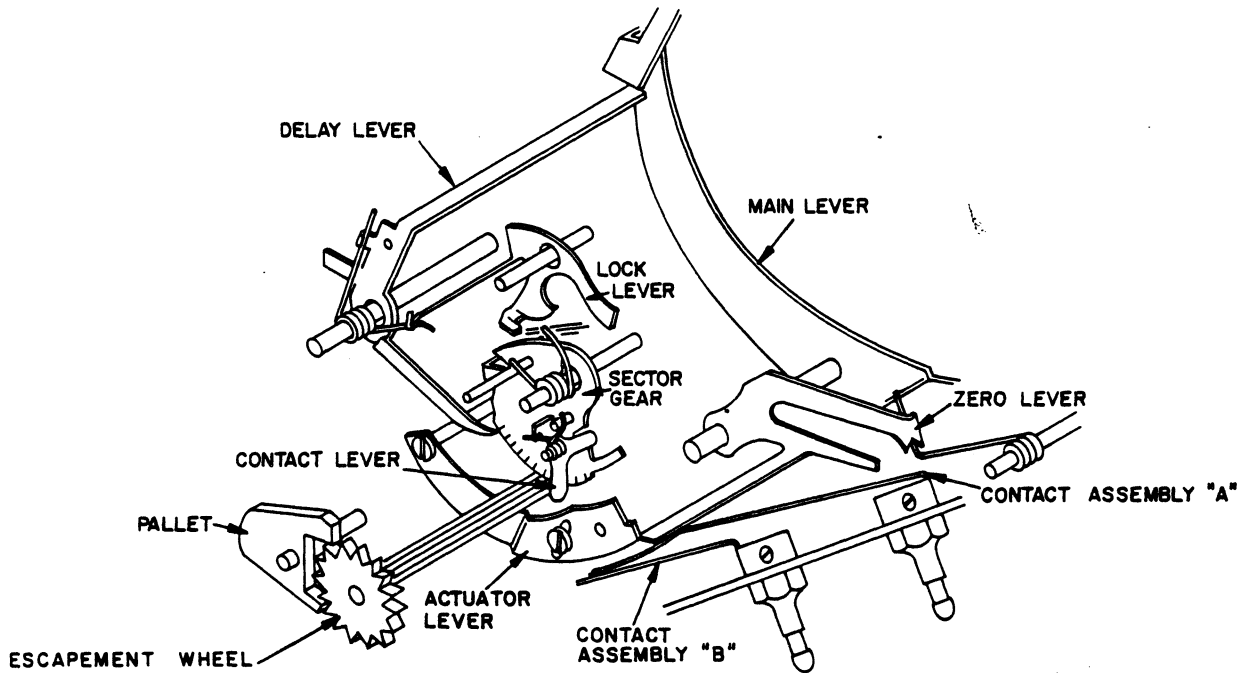

Figure 7. SYNCHRONIZER OPERATION

9. Cable Release Mechanism (fig. 3)

a. Cable Release Socket. The threaded cable release socket provides for attachment of a cable release and positions the cable release so that its plunger, when pushed, will pivot the cable release lever.

b. Cable Release Lever. When the shutter is cocked and the cable release lever is pushed, the cable release lever pivots and, in turn, pivots the release lever. Shutter action is the same as described in paragraph 4.

10. Synchronizer Operation (fig. 7)

a. Sync Lever Set to the "F-X" Position. When the sync lever is set to the "F-X" position and the shutter is tripped, the main lever pivots the zero lever, positioning contact assembly "A" so that it touches contact assembly "B" at the instant the shutter blades are fully open.

b. Sync Lever Set at Red "M" Position. When the sync lever is set to the red "M" position and the shutter is cocked, the main lever pivots the sector gear clockwise, engaging it with the lock lever. As

the sector gear pivots it allows the delay lever to move into a position which will, when the shutter is tripped, prevent the main lever from opening the shutter blades until the sector gear has pivoted. When the shutter is tripped the main lever releases the sector gear. As the sector gear pivots counterclockwise, it is retarded by the back and forth motion of the pallet acting on the escapement wheel which meshes with the sector gear. As the sector gear pivots it causes the contact lever to sweep against the actuator lever. The actuator lever pivots and positions contact assembly "A" so that it touches contact assembly "B" 8 to 12 milliseconds before the shutter blades are fully open. The sector gear, in pivoting counterclockwise, also pivots the delay lever which allows the main lever to continue its travel and open the shutter blades.

c. Sync Lever Set to the Black "M" Position. When the sync lever is set to the black "M" position the synchronizer operation is the same as in paragraph 10. b. except that the actuator lever is repositioned, thereby changing its point of contact with the contact lever. The point of contact is made 16-20 milliseconds before the shutter blades are fully opened.

Section II. TROUBLESHOOTING

11. General Information

If the shutter operates erratically a complete operational test is required to determine the extent of shutter malfunction. The operational test consists of operating the shutter with the controls set in various positions. Procedures for checking shutter speeds and synchronism mechanism are given in paragraphs

42, 43 and 44. The Troubleshooting Chart below lists commonly encountered troubles and indicates corrective repairs and adjustments. Disassemble only as needed for repairs. Before disassembly, check for loose or missing screws, springs that have come unhooked, or parts that are binding because of misalignment or lack of lubrication.

GRAPHEX SHUTTERS

SYMPTOM	PROBABLE TROUBLE	CORRECTION
Sluggish blade action	<p>Weak blade lever spring</p> <p>Dirty blade lever</p> <p>Bent revolving ring assembly</p> <p>Dirty revolving ring assembly</p>	<p>Replace blade lever spring (#1 Shutter, 2, fig. 12) (#2 & #3 Shutters, 2, fig. 18)</p> <p>Remove and clean blade lever (#1 Shutter, 4, fig. 12) (#2 & #3 Shutters, 4, fig. 18)</p> <p>Straighten revolving ring assembly (#1 Shutter, 2, fig. 13) (#2 & #3 Shutters, 3, fig. 19)</p> <p>Clean revolving ring assembly (#1 Shutter, 2, fig. 13) (#2 & #3 Shutters, 3, fig. 19)</p> <p>Clean track in diaphragm plate and leaf assembly (#1 Shutter, 5, fig. 13) (#2 & #3 Shutters, 5, fig. 19)</p>
Locked blades	<p>Blades slide under a revolving ring stud</p> <p>Loose blade lever screw</p>	<p>Replace revolving ring assembly (#1 Shutter, 2, fig. 13) (#2 & #3 Shutters, 3, fig. 19)</p> <p>Tighten blade lever screw (#1 Shutter, 3, fig. 12) (#2 & #3 Shutters, 3, fig. 18)</p>
Stiff diaphragm movement; buckled diaphragm leaves	<p>Grease or dirt on diaphragm leaves</p> <p>Diaphragm leaf or leaves have jumped guide slots</p>	<p>Remove diaphragm plate and leaf assembly (#1 Shutter, 5, fig. 13) (#2 & #3 Shutters, 5, fig. 19) from the shutter and clean diaphragm leaves. Replace diaphragm leaves if bent.</p> <p>Replace damaged leaves, or replace with new diaphragm plate and leaf assembly</p>
Sluggish shutter action with synchronizer off or on	<p>Weak or broken main lever spring</p> <p>Weak or broken auxiliary spring</p> <p>Retarding section dirty and/or damaged</p>	<p>Replace main lever spring (#1 Shutter, 6, fig. 11) (#2 & #3 Shutters, 14, fig. 17)</p> <p>Replace auxiliary spring (#2 & #3 Shutters, 12, fig. 17)</p> <p>Clean and lubricate retarding section. Replace damaged escapement wheel (#1 Shutter, 16, fig. 12) (#2 & #3 Shutters, 14, fig. 18). Retarding wheel assembly (#1 Shutter, 15, fig. 12) (#2 & #3 Shutters 13, fig. 18). Center wheel assembly (#2 & #3 Shutters, 15, fig. 18). Retarding lever assembly (#1 Shutter, 7, fig. 12) (#2 & #3 Shutters, 11, fig. 18)</p>
Sluggish shutter action with synchronizer on "M"	<p>Dirty or damaged synchronizer escapement wheel assembly and synchronizer pallet</p> <p>Damaged sector gear</p>	<p>Clean or replace synchronizer escapement wheel assembly (#1 Shutter, 6, fig. 10) (#2 & #3 Shutters, 6, fig. 16) and synchronizer pallet (#1 Shutter, 7, fig. 10) (#2 & #3 Shutters, 5, fig. 16)</p> <p>Replace synchronizer subassembly (#1 Shutter, 18, fig. 10) (#2 & #3 Shutters, 15, fig. 16)</p>

GRAPHEX SHUTTERS

SYMPTOM	PROBABLE TROUBLE	CORRECTION
<p>Locked shutter action with synchronizer off or on</p>	<p>Pin on retarding wheel assembly loose or bent</p>	<p>Replace retarding wheel assembly (#1 Shutter, 15, fig. 12) (#2 & #3 Shutters, 13, fig. 18)</p>
	<p>Damaged retarding lever assembly</p>	<p>Replace retarding lever assembly (#1 Shutter, 7, fig. 12) (#2 & #3 Shutters, 11, fig. 18)</p>
	<p>Damaged retarding wheel assembly</p>	<p>Replace retarding wheel assembly (#1 Shutter, 15, fig. 12) (#2 & #3 Shutters, 13, fig. 18)</p>
	<p>Damaged escapement wheel assembly</p>	<p>Replace escapement wheel assembly (#1 Shutter, 16, fig. 12) (#2 & #3 Shutters, 14, fig. 18)</p>
	<p>Damaged center wheel assembly</p>	<p>Replace center wheel assembly (#2 & #3 Shutters, 15, fig. 18)</p>
	<p>Loose stud on pallet lever assembly</p>	<p>Replace pallet lever assembly (#1 Shutter, 21, fig. 12) (#2 & #3 Shutters, 17, fig. 18)</p>
	<p>Loose stud on revolving ring assembly</p>	<p>Replace revolving ring assembly (#1 Shutter 2, fig. 13) (#2 & #3 Shutters, 3, fig. 19)</p>
<p>Locked shutter action with synchronizer on</p>	<p>Sector gear damaged</p>	<p>Replace synchronizer subassembly (#1 Shutter, 18, fig. 10) (#2 & #3 Shutters, 15, fig. 16)</p>
	<p>Escapement wheel assembly damaged</p>	<p>Replace escapement wheel assembly (#1 Shutter, 16, fig. 11) (#2 & #3 Shutters, 14, fig. 18)</p>
	<p>Broken synchronizer pallet stud on synchronizer subassembly</p>	<p>Replace synchronizer subassembly (#1 Shutter, 18, fig. 10) (#2 & #3 Shutters, 15, fig. 16)</p>
	<p>Worn lock lever</p>	<p>Replace lock lever (#1 Shutter, 16, fig. 10) (#2 & #3 Shutters, 12, fig. 16)</p>
	<p>Clutch lever spring too strong</p>	<p>Weaken clutch lever spring at coil (#2 & #3 Shutters, 1, fig. 16)</p>
	<p>Delay lever sprung; not releasing main lever assembly</p>	<p>Replace delay lever (#1 Shutter, 3, fig. 10) (#2 & #3 Shutters, 10, fig. 15)</p>
	<p>Delay lever sprung; strikes the synchronizer pallet or spring, or strikes the main lever stud</p>	<p>Bend delay lever to clear (#1 Shutter, 3, fig. 10) (#2 & #3 Shutters 10, fig. 15)</p>
<p>Sector gear spring disengaged, weak or broken</p>	<p>Reengage or replace spring (#1 Shutter, 17, fig. 10) (#2 & #3 Shutters, 4, fig. 16)</p>	

GRAPHEX SHUTTERS

SYMPTOM	PROBABLE TROUBLE	CORRECTION
Synchronizer inoperative	Clutch lever spring disengaged, weak or broken	Reengage or replace spring (#2 & #3 Shutters, 1, fig. 16)
Shutter goes through time and bulb settings	Time and bulb levers bent	Remove from shutter and straighten time lever (#1 Shutter, 3, fig. 11) (#2 & #3 Shutters, 7, fig. 17) and bulb lever (#1 Shutter, 2, fig. 11) (#2 & #3 Shutters, 6, fig. 17)
	Bulb and time lever screw too tight	Select a bulb and time lever screw with smaller shoulder height (#1 Shutter, 1, fig. 11) (#2 & #3 Shutters, 5, fig. 17)
	Lug on time lever presses too hard against slot in speed cam assembly, causing bending action on bulb lever	Bend lug on time lever slightly (#1 Shutter, 3, fig. 11) (#2 & #3 Shutters, 7, fig. 17)
	Angle of lug on main lever not parallel to end faces of bulb and time levers	Bend lug on main lever slightly until parallel with end faces of bulb and time levers (#1 Shutter, 7, fig. 11) (#2 & #3 Shutters, 15, fig. 17)
Synchronizer goes through when cocking shutter with synchronizer set at black or red "M"	Worn synchronizer stud on main lever	Replace main lever assembly (#1 Shutter, 7, fig. 11) (#2 & #3 Shutters, 15, fig. 17)
	Delay and lock lever spring disengaged, weak, or broken	Reengage or replace spring (#1 Shutter, 1, fig. 10) (#2 & #3 Shutters, 8, fig. 15)
	Dirty or damaged lock lever	Clean or replace lock lever (#1 Shutter, 16, fig. 10) (#2 & #3 Shutters, 12, fig. 16)
	Worn or broken sector gear	Replace synchronizer subassembly (#1 Shutter, 18, fig. 10) (#2 & #3 Shutters, 15, fig. 16)
No contact at any delay setting of synchronizer	Contact assemblies A & B too far apart	Bend contact points on contact assembly A to make contact (#1 Shutter, 2, fig. 9) (#2 & #3 Shutters, 2, fig. 15)
No contact at black or red "M" setting of synchronizer	Contact lever spring disengaged, weak, or broken	Reengage or replace spring (#1 Shutter, 19, fig. 10) (#2 & #3 Shutters, 16, fig. 16)
No contact at F-X setting on synchronizer	Zero lever spring disengaged or broken	Reengage or replace spring (#1 Shutter, 14, fig. 10) (#2 & #3 Shutters, 8, fig. 17)
	Zero lever assembly not engaging stud on main lever	Bend zero lever assembly slightly for proper engagement (#1 Shutter, 13, fig. 10) (#2 & #3 Shutters, 10, fig. 16)
	Bent lug on zero lever assembly	Bend lug on zero lever assembly to close contacts when shutter blades are open. Replace zero lever assembly if necessary (#1 Shutter, 13, fig. 10) (#2 & #3 Shutters, 10, fig. 16)
Incorrect synchroniztion	Weak sector gear spring	Replace spring (#1 Shutter, 17, fig. 10) (#2 & #3 Shutters, 4, fig. 16)

GRAPHEX SHUTTERS

SYMPTOM	PROBABLE TROUBLE	CORRECTION
Electrical shorts	Contact assemblies out of line	Align contact assemblies (#1 Shutter, 2 & 3, fig. 9) (#2 & #3 Shutters, 2 & 3, fig. 15)
	Cracked insulator block	Replace insulator block (#1 Shutter, 6, fig. 9) (#2 & #3 Shutters, 6, fig. 15)
	Cracked prong insulators	Replace prong insulators (#1 Shutter, 7, fig. 9) (#2 & #3 Shutters, 7, fig. 15)

NOTES

Section III. LENS AND SHUTTER ASSEMBLY REPAIR AND ALIGNMENT

11. Parts Replacement

Part numbers for all replacement parts are included in the Legend for all illustrations of the shutters involved. When ordering parts for replacement, include the part number and the item name and direct all orders to Wollensak Optical Co., Rochester, New York.

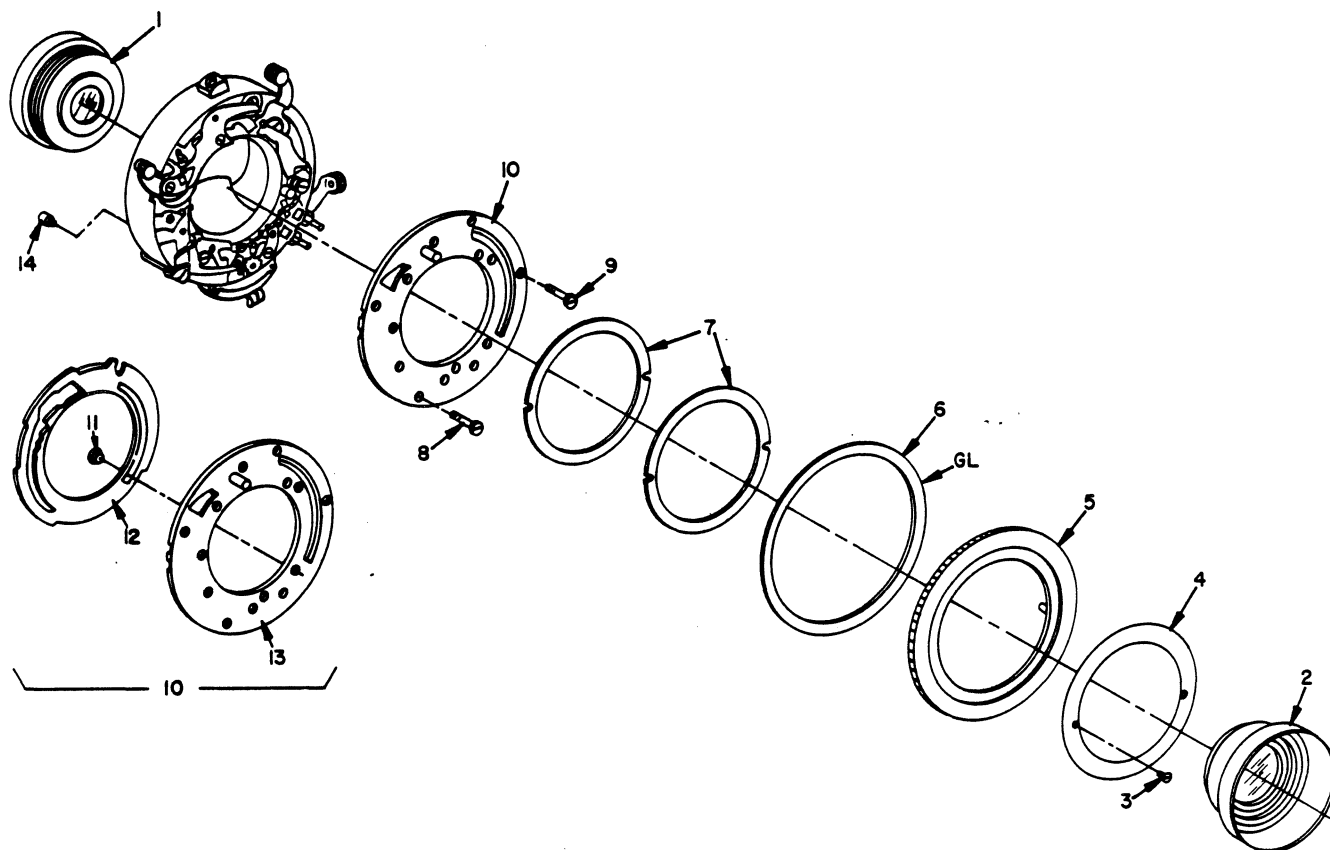

Figure 8. NO. 1 SHUTTER, DISASSEMBLY - STAGE 1

Legend for Figure 8

- | | | | |
|----|-----------------------------------|-----|--|
| 1. | Rear Lens | 7. | Nameplate spacer rings, p/n 03004400 |
| 2. | Front Lens | 8. | Front case screw (long) p/n 108-S |
| 3. | Nameplate Screw, p/n 603-S | 9. | Front case screw (short) p/n 602-S |
| 4. | Nameplate | 10. | Case and cam assembly, p/n 02096900 |
| | 101MM f/4.5, p/n 03090730 | 11. | Cam screw, p/n 135-S (part of item 10) |
| | 90MM f/6.8, p/n 03090720 | 12. | Speed cam assembly, p/n 02096010 (part of item 10) |
| | 65MM f/6.8, p/n 03094790 | 13. | Front case, p/n 03090350 (part of item 10) |
| 5. | Speed ring assembly, p/n 02090970 | 14. | Locating pin, p/n 151-S |
| 6. | Speed ring spacer, p/n 03090360 | | Jamb Nut, p/n 03062490 (used for mounting - not shown) |

GRAPHEX SHUTTERS

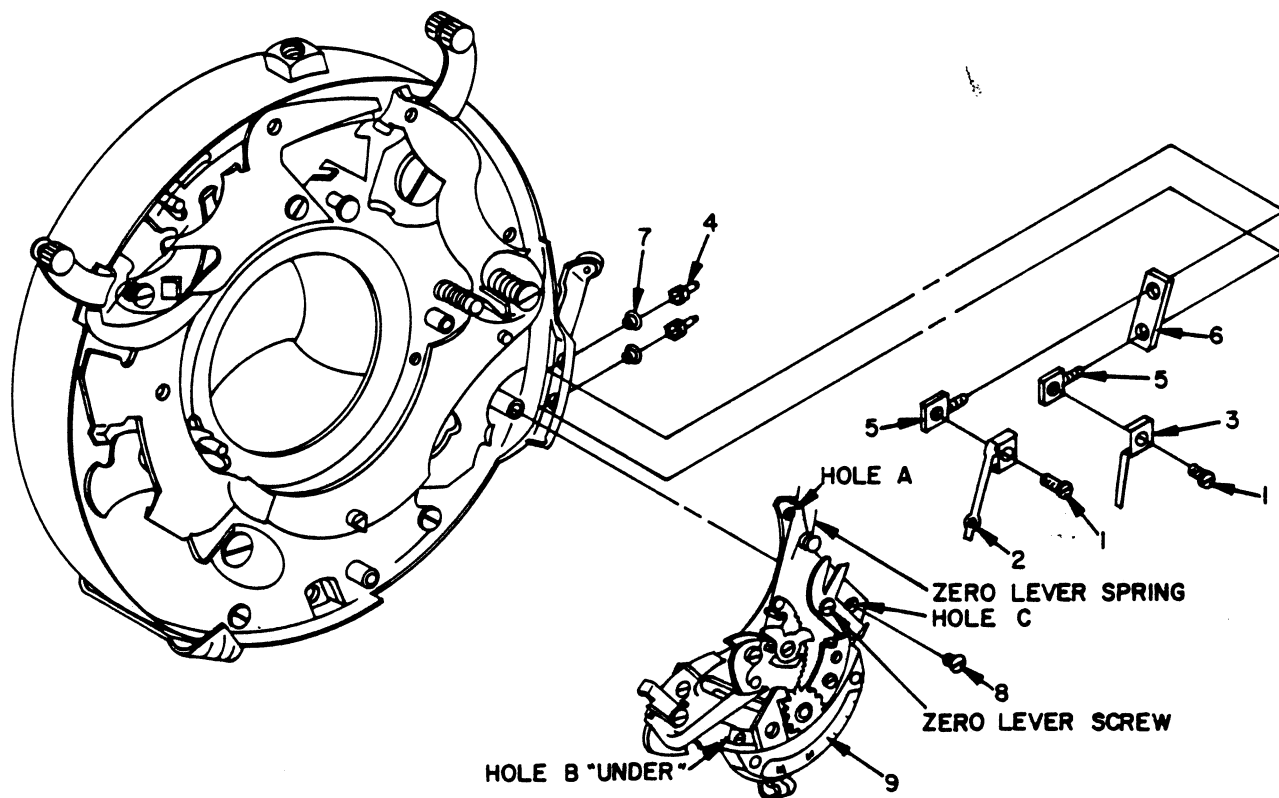

Figure 9. NO. 1 SHUTTER, DISASSEMBLY - STAGE 2

Legend for Figure 9

- | | | | |
|----|------------------------------------|----|-------------------------------------|
| 1. | Contact screw, p/n 523-S | 6. | Insulator block, p/n 07094800 |
| 2. | Contact assembly "A", p/n 02096570 | 7. | Prong insulator, p/n 153-B |
| 3. | Contact assembly "B", p/n 02096260 | 8. | Synchronizer screw, p/n 529-S |
| 4. | Prong, p/n 616-S | 9. | Synchronizer assembly, p/n 02096880 |
| 5. | Prong screw, p/n 520-S | | |

GRAPHEX SHUTTERS

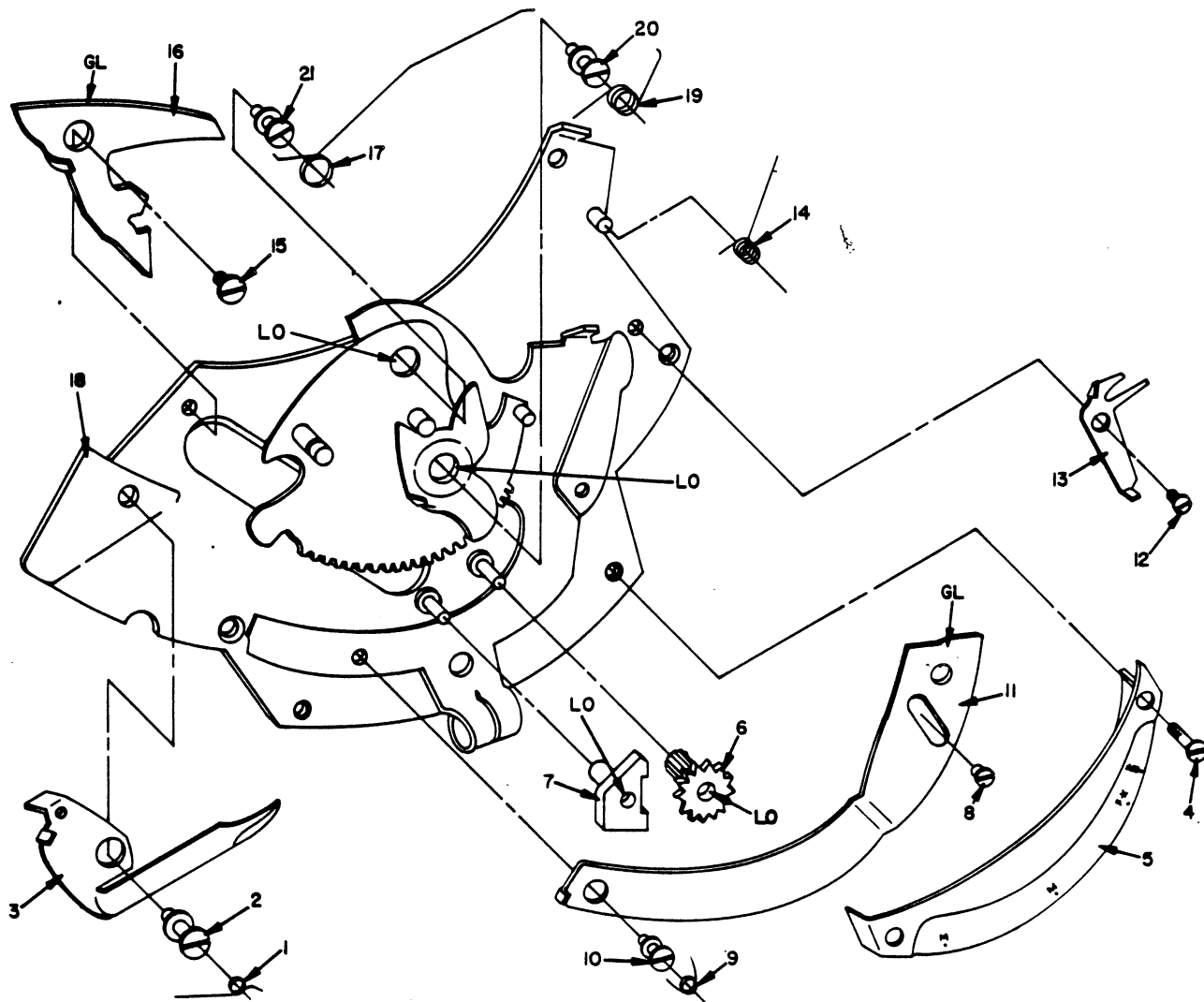

Figure 10. NO. 1 SHUTTER, DISASSEMBLY - STAGE 3

Legend for Figure 10

- | | | | |
|-----|--|-----|--|
| 1. | Delay and lock lever spring, p/n 03090590 | 13. | Zero lever, p/n 03090250 |
| 2. | Delay lever screw, p/n 604-S | 14. | Zero lever spring, p/n 03090600 |
| 3. | Delay lever, p/n 03090240 | 15. | Lock lever screw, p/n 522-S |
| 4. | Millisecond scale screw, p/n 597-S | 16. | Lock lever, p/n 03090330 |
| 5. | Millisecond scale, p/n 03090340 | 17. | Sector gear spring, p/n 03090580 |
| 6. | Synchronizer escapement wheel assembly, p/n 02007720 | 18. | Synchronizer subassembly, p/n 02009300 |
| 7. | Synchronizer pallet, p/n 03007770 | 19. | Contact lever spring, p/n 03090620 (part of item 18) |
| 8. | Actuator lever screw, p/n 588-S | 20. | Contact lever screw, p/n 598-S (part of item 18) |
| 9. | Actuator lever spring, p/n 03090610 | 21. | Sector gear screw, p/n 519-S (part of item 18) |
| 10. | Actuator pivot screw, p/n 601-S | | |
| 11. | Actuator lever, p/n 03090230 | | |
| 12. | Zero lever screw, p/n 605-S | | |

GRAPHEX SHUTTERS

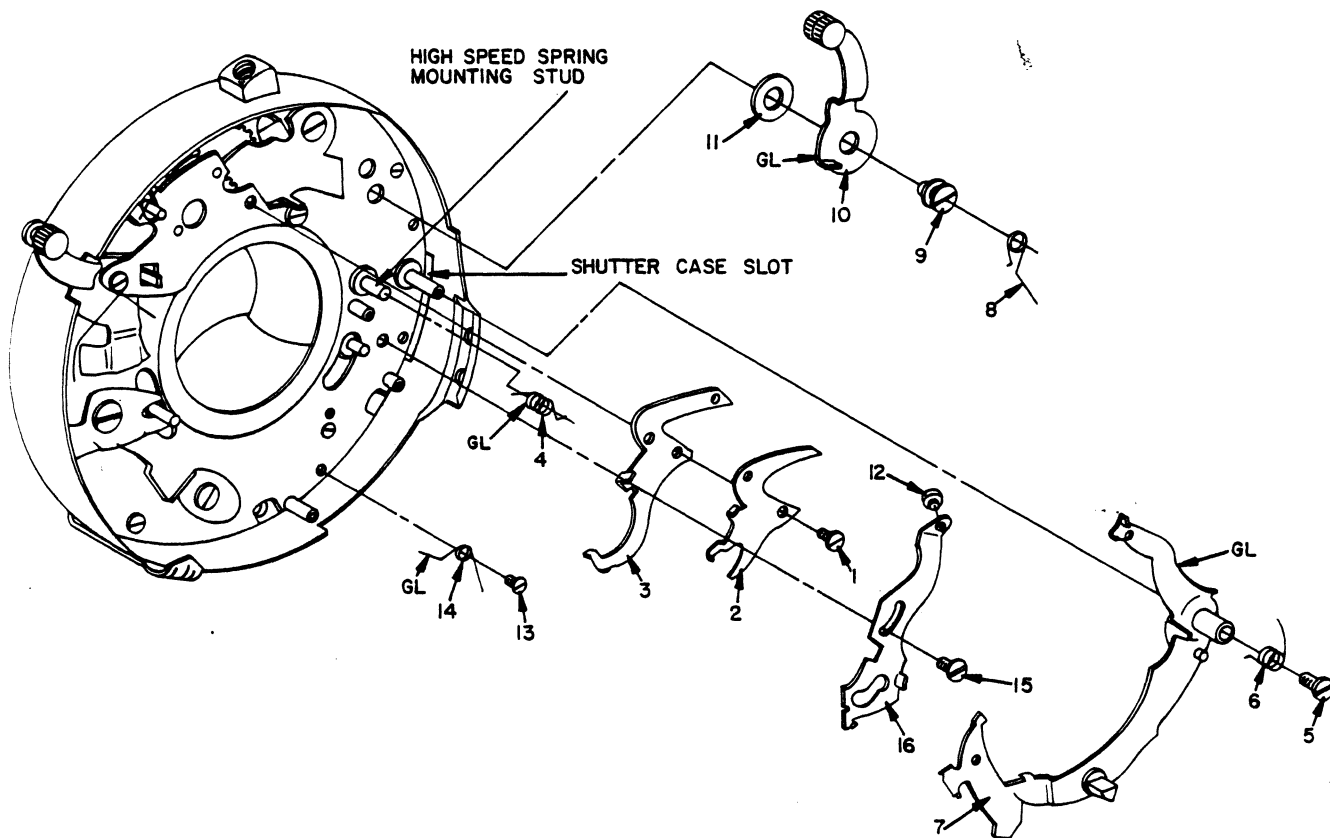

Figure 11. NO. 1 SHUTTER, DISASSEMBLY - STAGE 4

Legend for Figure 11

- | | | | |
|----|--------------------------------------|-----|--------------------------------------|
| 1. | Bulb and time lever screw, p/n 116-S | 9. | Cocking lever screw, p/n 39-S |
| 2. | Bulb lever, p/n 03004430 | 10. | Cocking lever assembly, p/n 02095990 |
| 3. | Time lever, p/n 03004440 | 11. | Cocking lever washer, p/n 86-W |
| 4. | High speed spring, p/n 03005990 | 12. | Focus lever button, p/n 622-S |
| 5. | Main lever screw, p/n 608-S | 13. | Focus lever spring screw, p/n 414-S |
| 6. | Main lever spring, p/n 03005980 | 14. | Focus lever spring, p/n 03006040 |
| 7. | Main lever assembly, p/n 02090310 | 15. | Focus lever screw, p/n 145-S |
| 8. | Cocking lever spring, p/n 03006010 | 16. | Focus lever, p/n 03090320 |

GRAPHEX SHUTTERS

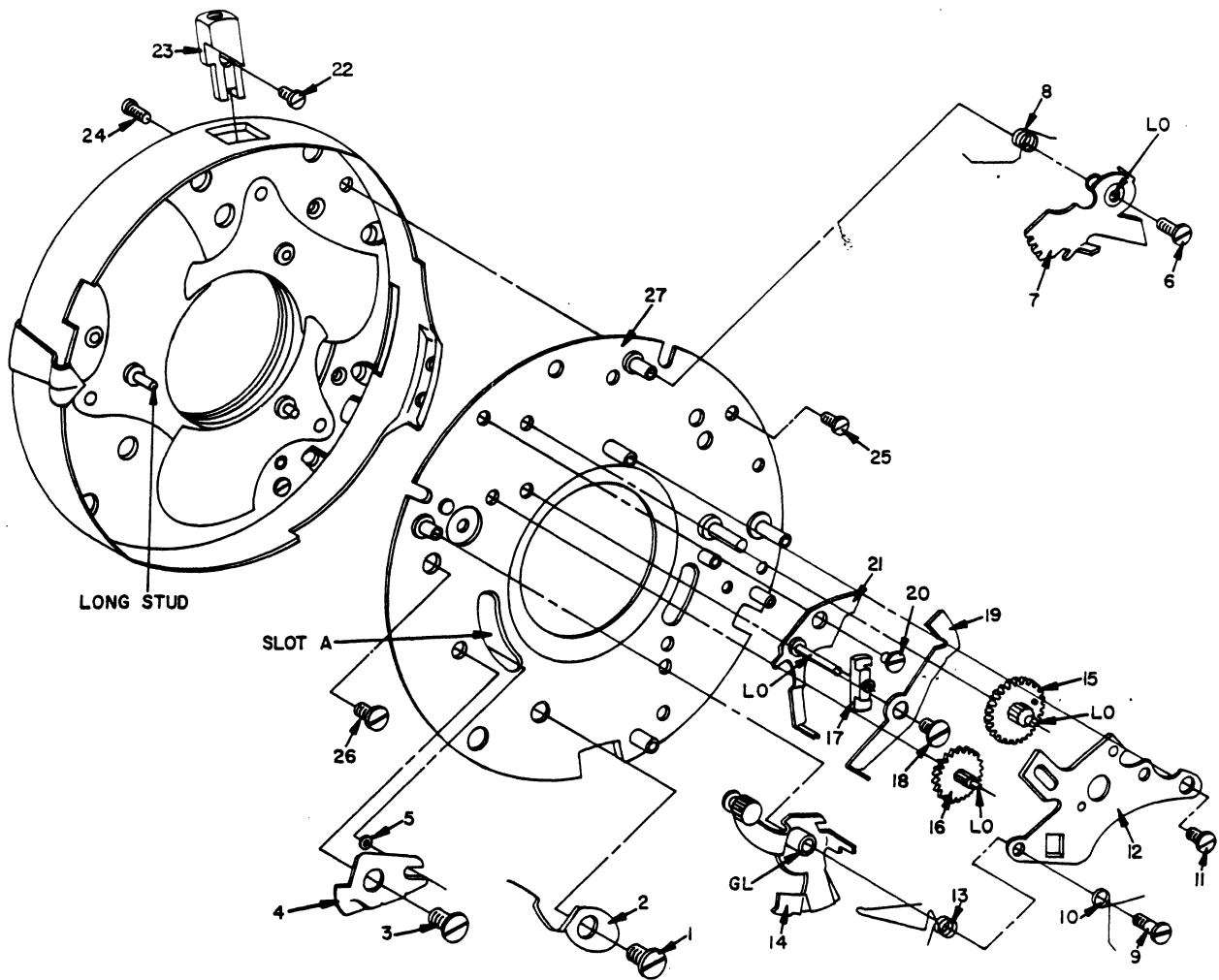

Figure 12. NO. 1 SHUTTER, DISASSEMBLY - STAGE 5

Legend for Figure 12

- | | | | |
|-----|--|-----|---|
| 1. | Blade lever spring screw, p/n 550-S | 15. | Retarding wheel assembly, p/n 02006600 |
| 2. | Blade lever spring, p/n 03004730 | 16. | Escapement wheel assembly, p/n 02006610 |
| 3. | Blade lever screw, p/n 164-S | 17. | Pallet, p/n 03006620 |
| 4. | Blade lever, p/n 03004280 | 18. | Cable release lever screw, p/n 131-S |
| 5. | Shutter blade stud washer, p/n 76-W | 19. | Cable release lever, p/n 03004330 |
| 6. | Retarding lever screw, p/n 14-S | 20. | Pallet lever screw, p/n 34-S |
| 7. | Retarding lever assembly, p/n 02095970 | 21. | Pallet lever assembly, p/n 02095920 |
| 8. | Retarding lever spring, p/n 03006000 | 22. | Cable release socket screw, p/n 52-S |
| 9. | Release lever screw, p/n 112-S | 23. | Cable release socket, p/n 152-B |
| 10. | Bulb and time lever spring, p/n 03008140 | 24. | Back case screw, p/n 427-S |
| 11. | Retarding device cover screw, p/n 14-S | 25. | Support plate screw (outer), p/n 40-S |
| 12. | Retarding device cover, p/n 03006580 | 26. | Support plate screw (inner), p/n 52-S |
| 13. | Release lever spring, p/n 03097490 | 27. | Support plate assembly, p/n 02091150 |
| 14. | Release lever assembly, p/n 02090470 | | |

GRAPHEX SHUTTERS

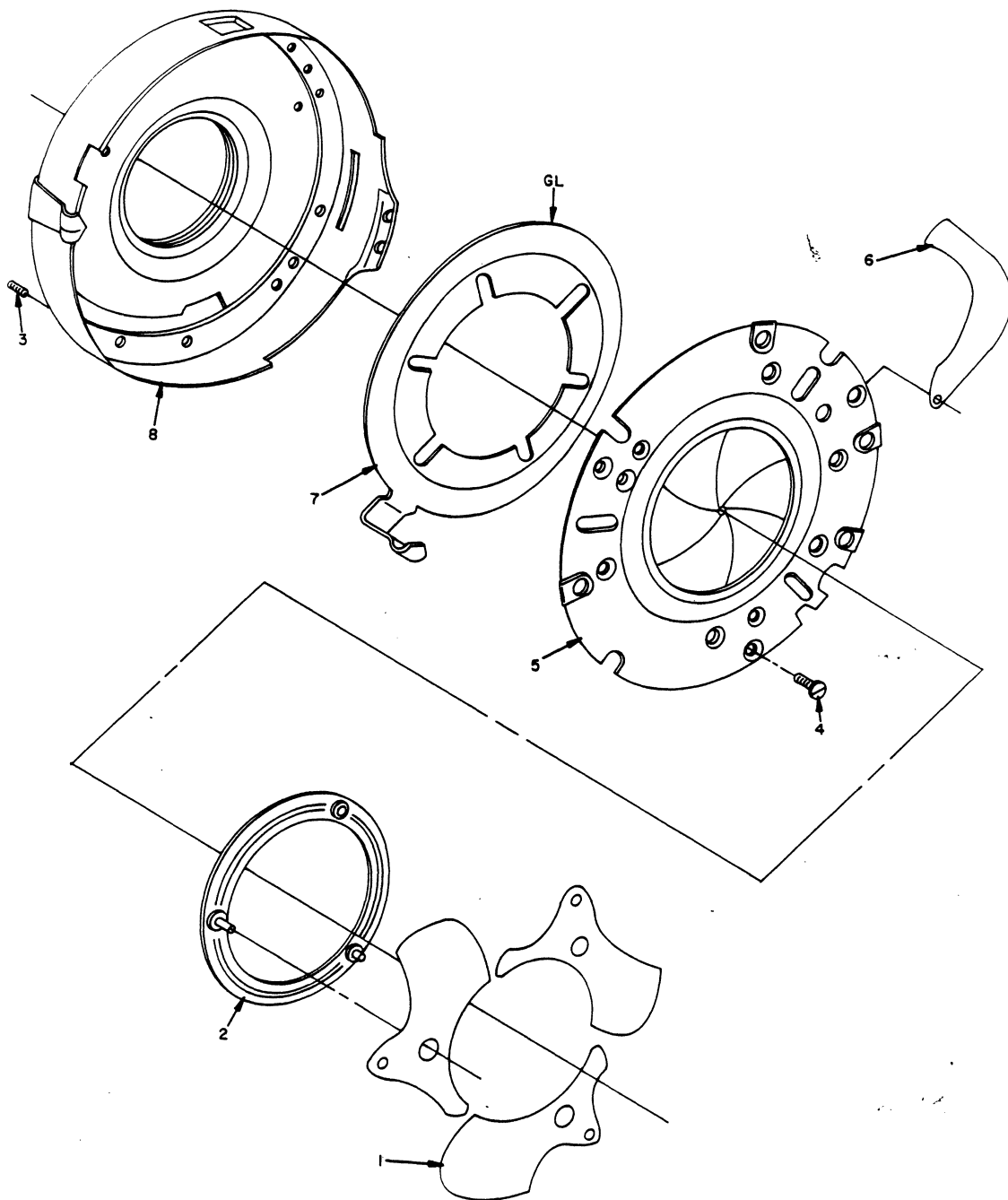

Figure 13. NO. 1 SHUTTER, DISASSEMBLY - STAGE 6

Legend for Figure 13

- | | | | |
|----|---|----|---|
| 1. | Shutter blade assembly, p/n 02095910 | 6. | Diaphragm leaf, p/n 03004210 (part of item 5) |
| 2. | Revolving ring assembly, p/n 02095900 | 7. | Diaphragm indicator ring, p/n 03090400 |
| 3. | Diaphragm stop screw, p/n 376-S | 8. | Shutter case |
| 4. | Diaphragm plate screw, p/n 65-S | | |
| 5. | Diaphragm plate and leaf assembly, p/n 02096970 | | |

GRAPHEX SHUTTERS

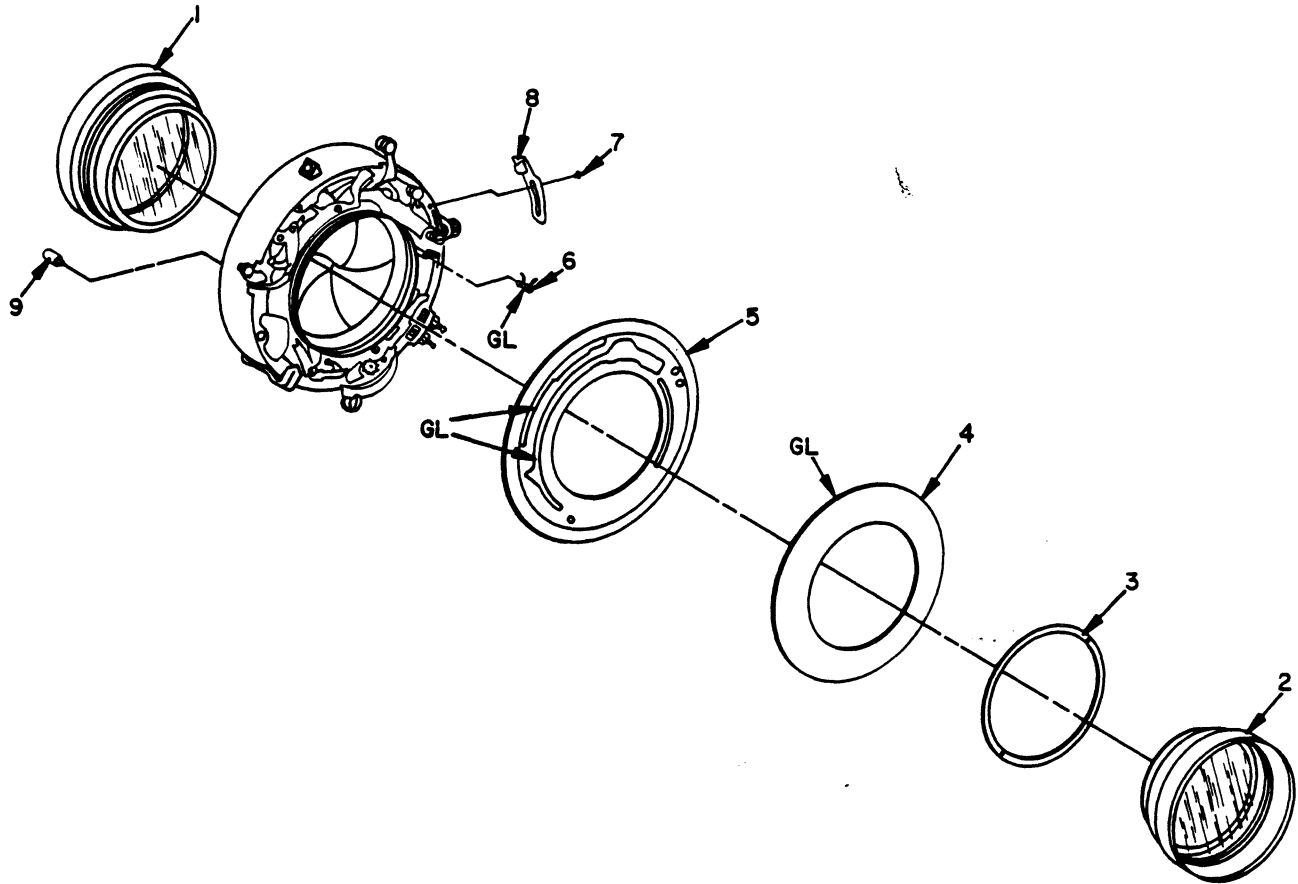

Figure 14. NO. 2 AND 3 SHUTTER, DISASSEMBLY - STAGE 1

Legend for Figure 14

- | | | | |
|----|-----------------------------------|----------------------|---|
| 1. | Rear Lens | 152MM f/4.5 | |
| 2. | Front Lens | (No. 3) p/n 03090890 | |
| 3. | Nameplate locking ring | 5. | Speed Cam Assembly |
| | (No. 2) p/n 03007420 | | (No. 2) p/n 02098630 |
| | (No. 3) p/n 03006500 | | (No. 3) p/n 02009150 |
| 4. | Nameplate | 6. | High speed spring, p/n 03006140 |
| | 127MM f/4.5 | 7. | Dust shield screw |
| | (No. 2) p/n 03008300 | | (No. 2) p/n 515-S |
| | 127MM f/4.5 | | (No. 3) p/n 433-S |
| | (No. 2 w/Ektar lens) p/n 03008470 | 8. | Dust shield |
| | 135MM f/4.7 | | (No. 2) p/n 03007940 |
| | (No. 2) p/n 03102980 | | (No. 3) p/n 03006510 |
| | 202MM f/5.6 Telephoto | 9. | Locating pin |
| | (No. 2) p/n 03097570 | | (No. 2) p/n 516-S |
| | 162MM f/4.5 | | (No. 3) p/n 151-S |
| | (No. 3) p/n 03009860 | | Jamb nut (used for mounting, not shown) |
| | 203MM f/7.5 Telephoto | | (No. 2) p/n 03060090 |
| | (No. 2) p/n 03099400 | | (No. 3) p/n 03062550 |

GRAPHEX SHUTTERS

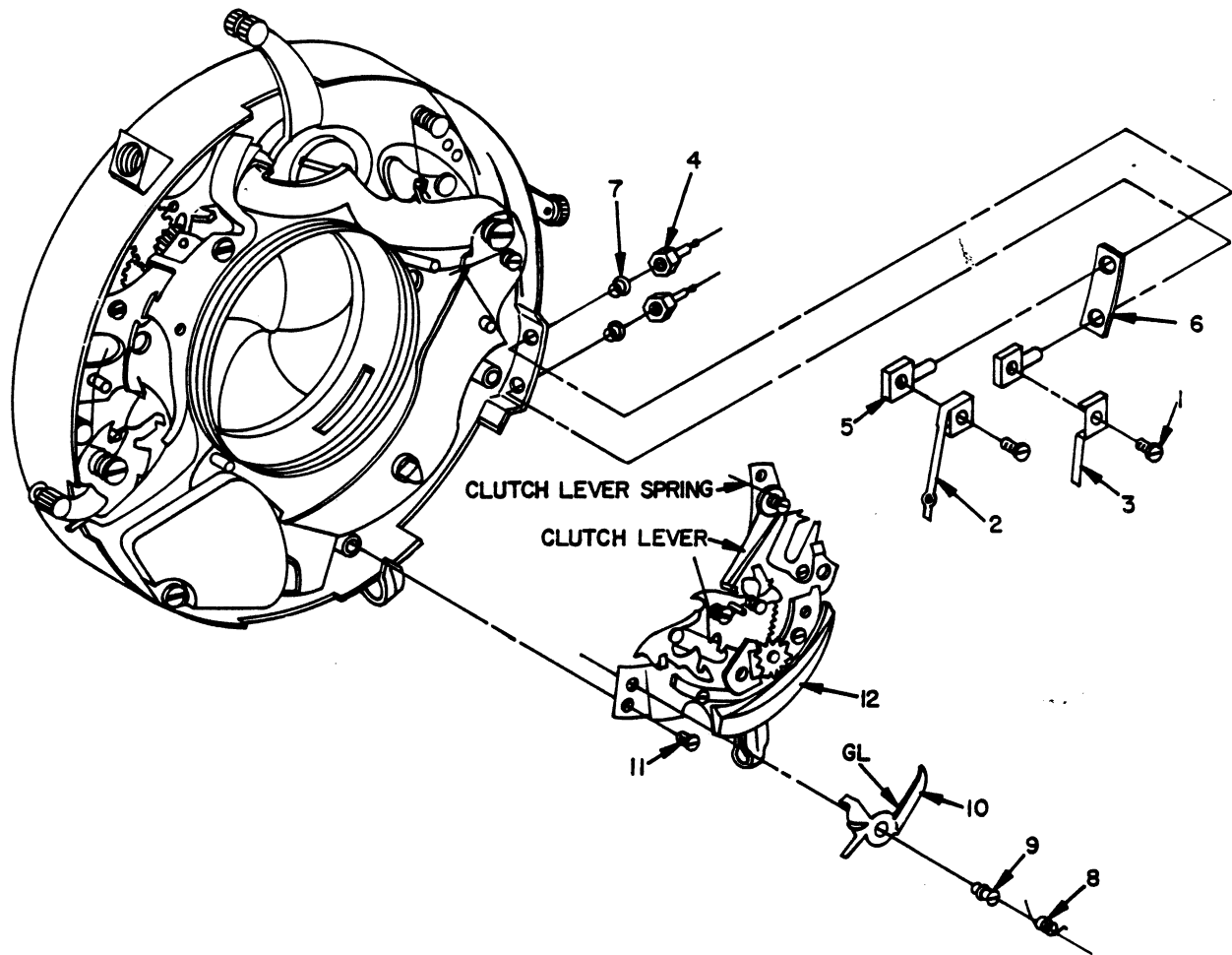

Figure 15. NO. 2 AND 3 SHUTTER, DISASSEMBLY - STAGE 2

Legend for Figure 15

- | | | | |
|----|--|-----|---|
| 1. | Contact screw, p/n 523-S | 7. | Prong insulator, p/n 153-B |
| 2. | Contact assembly "A"
(No. 2) p/n 02096570 | 8. | Delay and lock lever spring
(No. 2) p/n 03007870 (part of item 12)
(No. 3) p/n 03090830 (part of item 12) |
| 3. | Contact assembly "B"
(No. 2) p/n 02096260
(No. 3) p/n 02009140 | 9. | Delay lever screw, p/n 527-S (part of item 12) |
| 4. | Prong, p/n 616-S | 10. | Delay lever
(No. 2) p/n 03007820 (part of item 12)
(No. 3) p/n 03009880 (part of item 12) |
| 5. | Prong screw, p/n 520-S | 11. | Synchronizer support screw, p/n 528-S |
| 6. | Insulator block
(No. 2) p/n 07105270
(No. 3) p/n 07094800 | 12. | Synchronizer assembly
(No. 2) p/n 02096890
(No. 3) p/n 02098440 |

GRAPHEX SHUTTERS

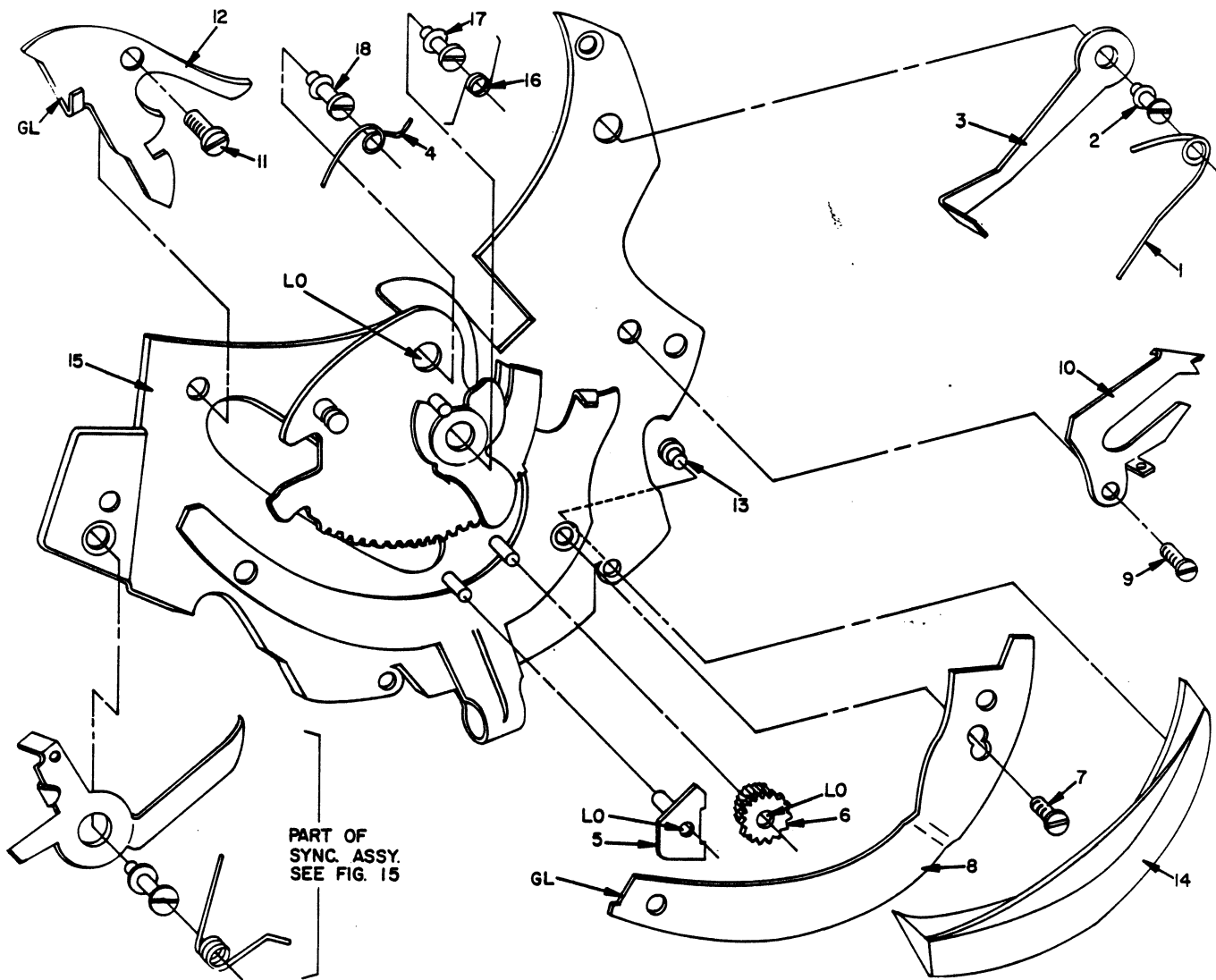

Figure 16. NO. 2 AND 3 SHUTTER, DISASSEMBLY - STAGE 3

Legend for Figure 16

- | | |
|---|--|
| 1. Clutch lever spring, p/n 03095200 | 11. Lock lever screw, p/n 522-S |
| 2. Clutch lever screw, p/n 662-S | 12. Lock lever |
| 3. Clutch lever, p/n 03095180 | (No. 2) p/n 03007810 |
| 4. Sector gear spring, p/n 03007850 | (No. 3) p/n 03090820 |
| 5. Synchronizer pallet, p/n 03007770 | 13. Millisecond scale screw, p/n 346-S |
| 6. Synchronizer escapement wheel assembly, p/n 02077720 | 14. Millisecond scale |
| 7. Actuator lever screw | (No. 2) p/n 03094170 |
| (No. 2) p/n 588-S | (No. 3) p/n 03098630 |
| (No. 3) p/n 522-S | 15. Synchronizer subassembly |
| 8. Actuator lever, p/n 03090570 | (No. 2) p/n 02099600 |
| 9. Zero lever screw | (No. 3) p/n 02098030 |
| (No. 2) p/n 656-S | 16. Contact lever spring, p/n 03090480 (part of item 15) |
| (No. 3) p/n 617-S | 17. Contact lever screw, p/n 518-S (part of item 15) |
| 10. Zero lever assembly | 18. Sector gear screw, p/n 519-S (part of item 15) |
| (No. 2) p/n 02098580 | |
| (No. 3) p/n 02009160 | |

GRAPHEX SHUTTERS

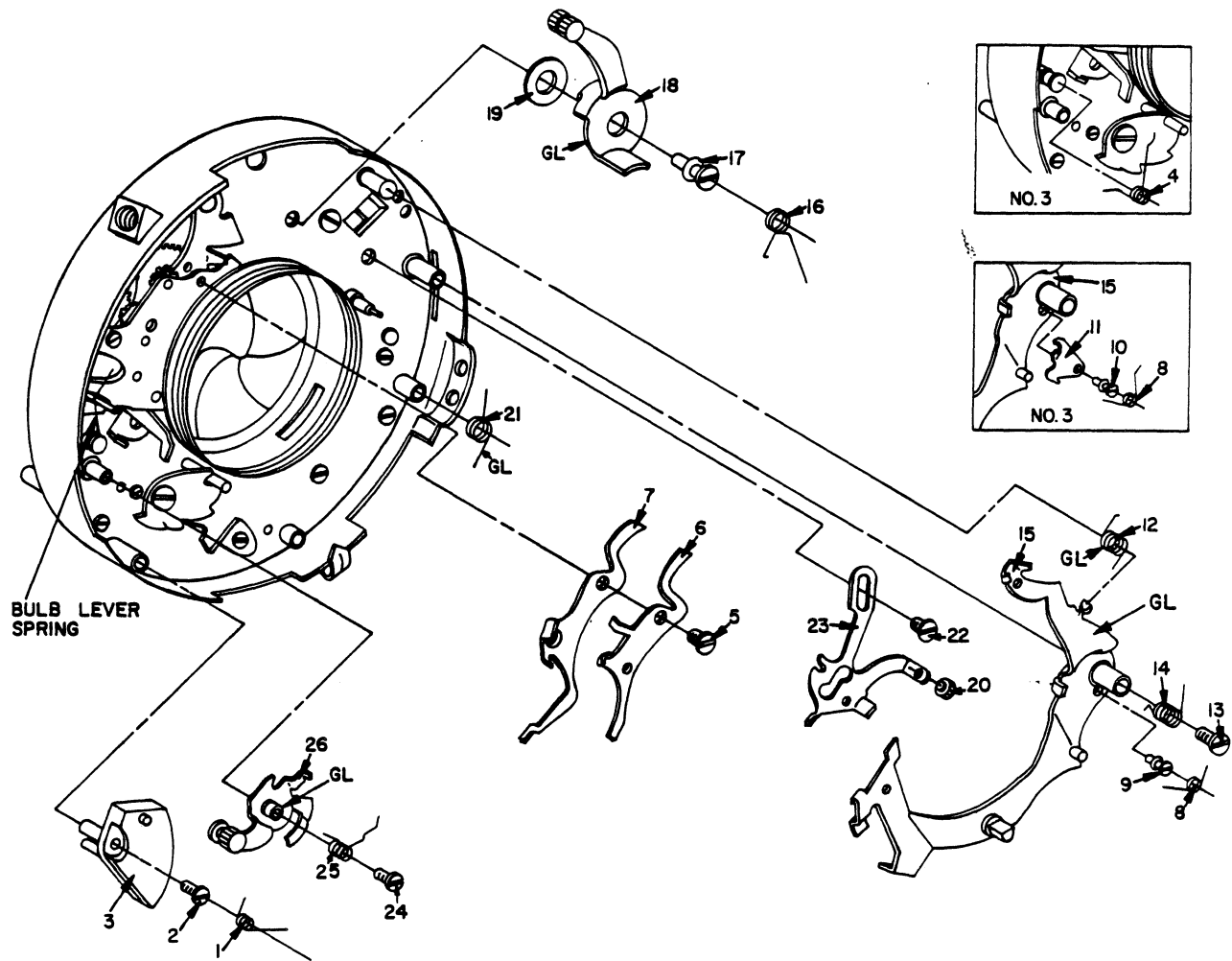

Figure 17. NO. 2 AND 3 SHUTTER, DISASSEMBLY - STAGE 4

Legend for Figure 17

- | | | | |
|-----|---|-----|---|
| 1. | Retarding weight spring, p/n 03008490 | 13. | Main lever screw, p/n 430-S |
| 2. | Retarding weight screw, p/n 579-S | 14. | Main lever spring
(No. 2) p/n 03007900
(No. 3) p/n 03006090 |
| 3. | Retarding weight assembly, p/n 02098370 | 15. | Main lever assembly
(No. 2) p/n 02007970
(No. 3) p/n 02090850 |
| 4. | Bulb and pallet lever spring
(No. 3) p/n 03006080 | 16. | Cocking lever spring, p/n 03006100 |
| 5. | Bulb and time lever screw, p/n 431-S | 17. | Cocking lever screw, p/n 39-S |
| 6. | Bulb lever
(No. 2) p/n 03094290
(No. 3) p/n 03006410 | 18. | Cocking lever assembly, p/n 02006700 |
| 7. | Time lever
(No. 2) p/n 03007500
(No. 3) p/n 03006400 | 19. | Cocking lever washer, p/n 86-W |
| 8. | Zero lever spring
(No. 2) p/n 03006170
(No. 3) p/n 03090840 | 20. | Focus lever button, p/n 622-S |
| 9. | Zero lever spring screw
(No. 2) p/n 425-S | 21. | Focus lever spring, p/n 03006150 |
| 10. | Stop lever screw
(No. 3) p/n 425-S | 22. | Focus lever screw, p/n 435-S |
| 11. | Stop lever
(No. 3) p/n 03006390 | 23. | Focus lever
(No. 2) p/n 03008310
(No. 3) p/n 03006460 |
| 12. | Auxiliary spring
(No. 2) p/n 03007920
(No. 3) p/n 03006130 | 24. | Release lever screw, p/n 14-S |
| | | 25. | Release and time lever spring
(No. 2) p/n 03003730
(No. 3) p/n 03006120 |
| | | 26. | Release lever assembly
(No. 2) p/n 02090010
(No. 3) p/n 02006720 |

GRAPHEX SHUTTERS

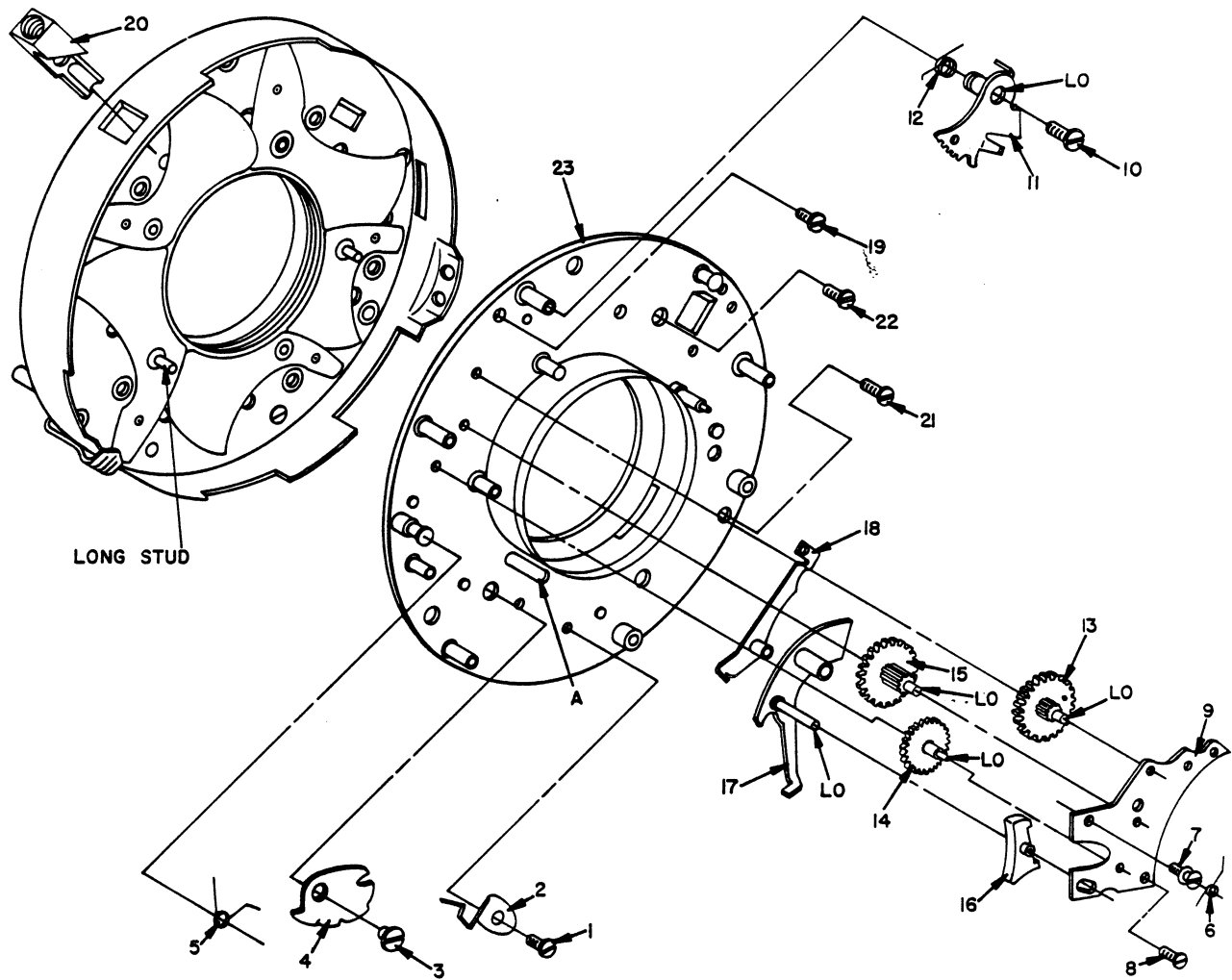

Figure 18. NO. 2 AND 3 SHUTTER, DISASSEMBLY - STAGE 5

Legend for Figure 18

- | | | | |
|-----|--|-----|--|
| 1. | Blade lever spring screw, p/n 550-S | 12. | Retarding lever spring
(No. 2) p/n 03007910
(No. 3) p/n 03006110 |
| 2. | Blade lever spring, p/n 03004730 | 13. | Retarding wheel assembly, p/n 02006350 |
| 3. | Blade lever screw, p/n 429-S | 14. | Escapement wheel assembly, p/n 02006370 |
| 4. | Blade lever
(No. 2) p/n 03105640
(No. 3) p/n 03006480 | 15. | Center wheel assembly, p/n 02006360 |
| 5. | Pallet lever spring
(No. 2) p/n 03094620 | 16. | Pallet
(No. 2) p/n 03007980
(No. 3) p/n 03006520 |
| 6. | Bulb lever spring
(No. 2) p/n 03094630 | 17. | Pallet lever assembly
(No. 2) p/n 02098390
(No. 3) p/n 02006680 |
| 7. | Retarding device cover screw (large)
(No. 2) p/n 579-S
(No. 3) p/n 144-S | 18. | Cable release lever assembly
(No. 2) p/n 02098270
(No. 3) p/n 02006690 |
| 8. | Retarding device cover (small), p/n 84-S | 19. | Cable release socket screw, p/n 52-S |
| 9. | Retarding device cover
(No. 2) p/n 03007450
(No. 3) p/n 03006380 | 20. | Cable release socket, p/n 151-B |
| 10. | Retarding lever screw, p/n 14-S | 21. | Support plate screw (long) p/n 427-S |
| 11. | Retarding lever assembly
(No. 2) p/n 02098340
(No. 3) p/n 02006730 | 22. | Support plate screw (short) p/n 426-S |
| | | 23. | Support plate assembly
(No. 2) p/n 02105710
(No. 3) p/n 02091010 |

GRAPHEX SHUTTERS

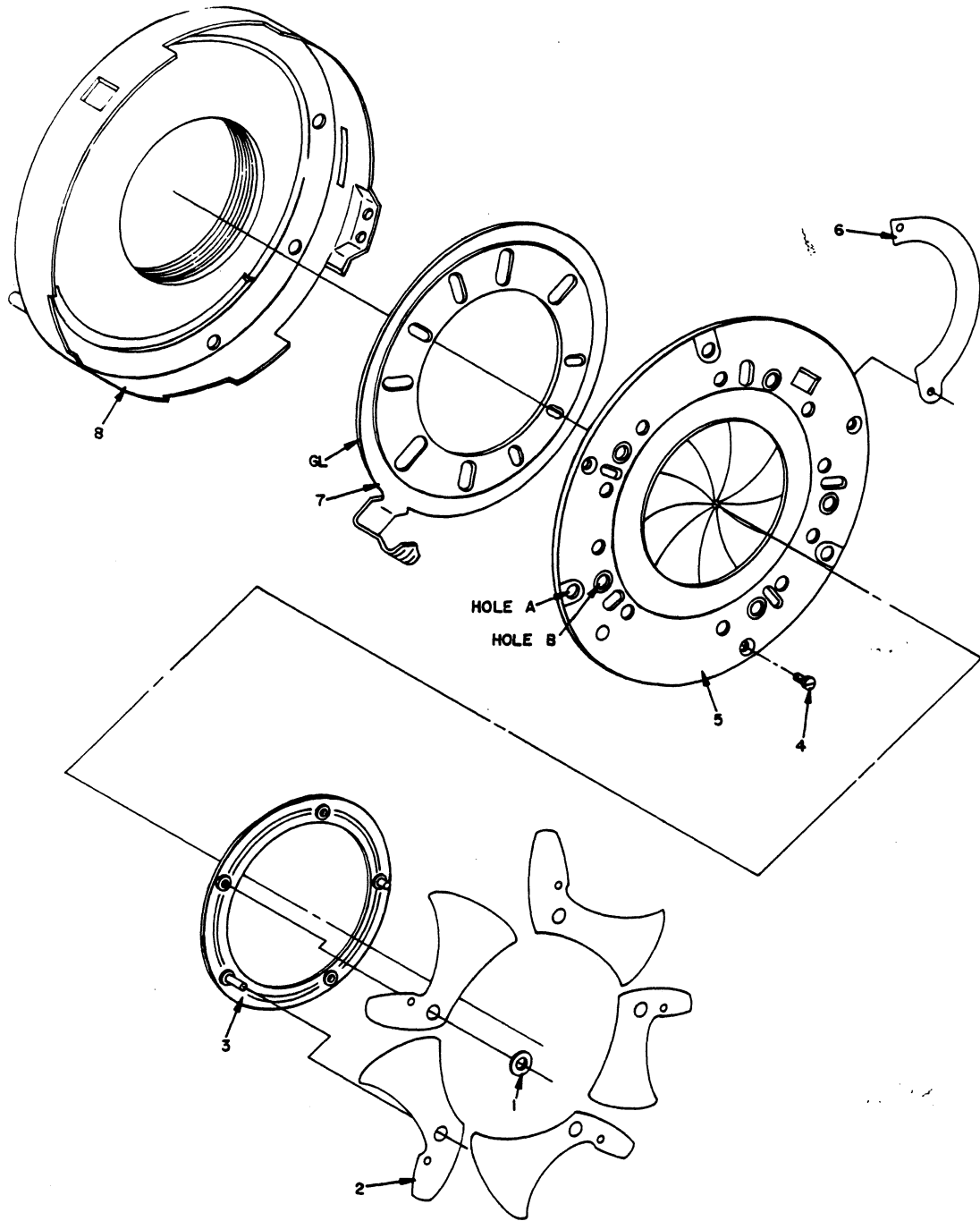

Figure 19. NO. 2 AND 3 SHUTTER, DISASSEMBLY - STAGE 6

Legend for Figure 19

- | | | | |
|----|---|----|--|
| 1. | Blade separator washer, p/n 78-W | 5. | Diaphragm plate and leaf assembly
(No. 2) p/n 02098240
(No. 3) p/n 02006630 |
| 2. | Shutter blade assembly
(No. 2) p/n 02098260
(No. 3) p/n 02006650 | 6. | Diaphragm leaf
(No. 2) p/n 03007410 (part of item 5)
(No. 3) p/n 03006270 (part of item 5) |
| 3. | Revolving ring assembly
(No. 2) p/n 02098250
(No. 3) p/n 02006640 | 7. | Diaphragm indicator ring
(No. 2) p/n 03007950
(No. 3) p/n 03006260 |
| 4. | Diaphragm plate screw, p/n 428-S | 8. | Shutter case |

GRAPHEX SHUTTERS

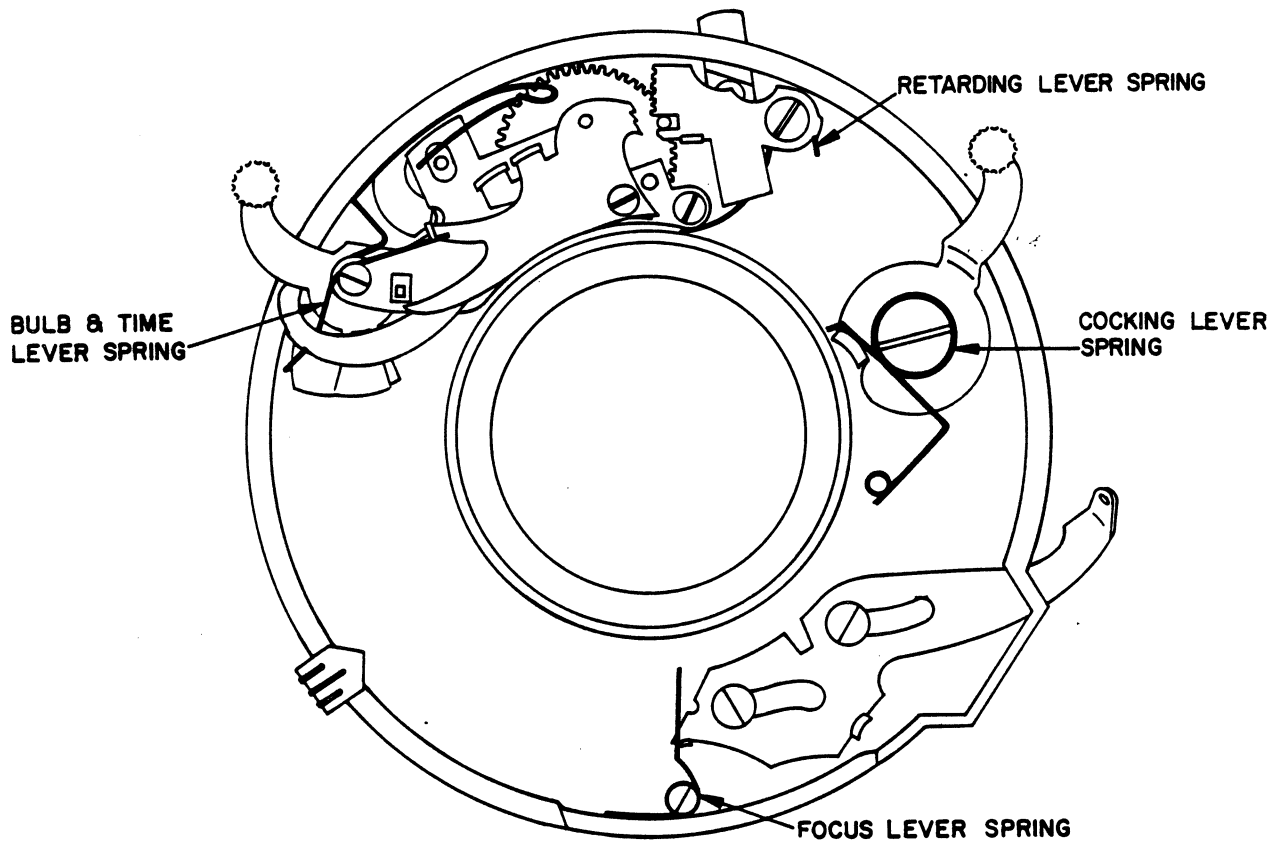
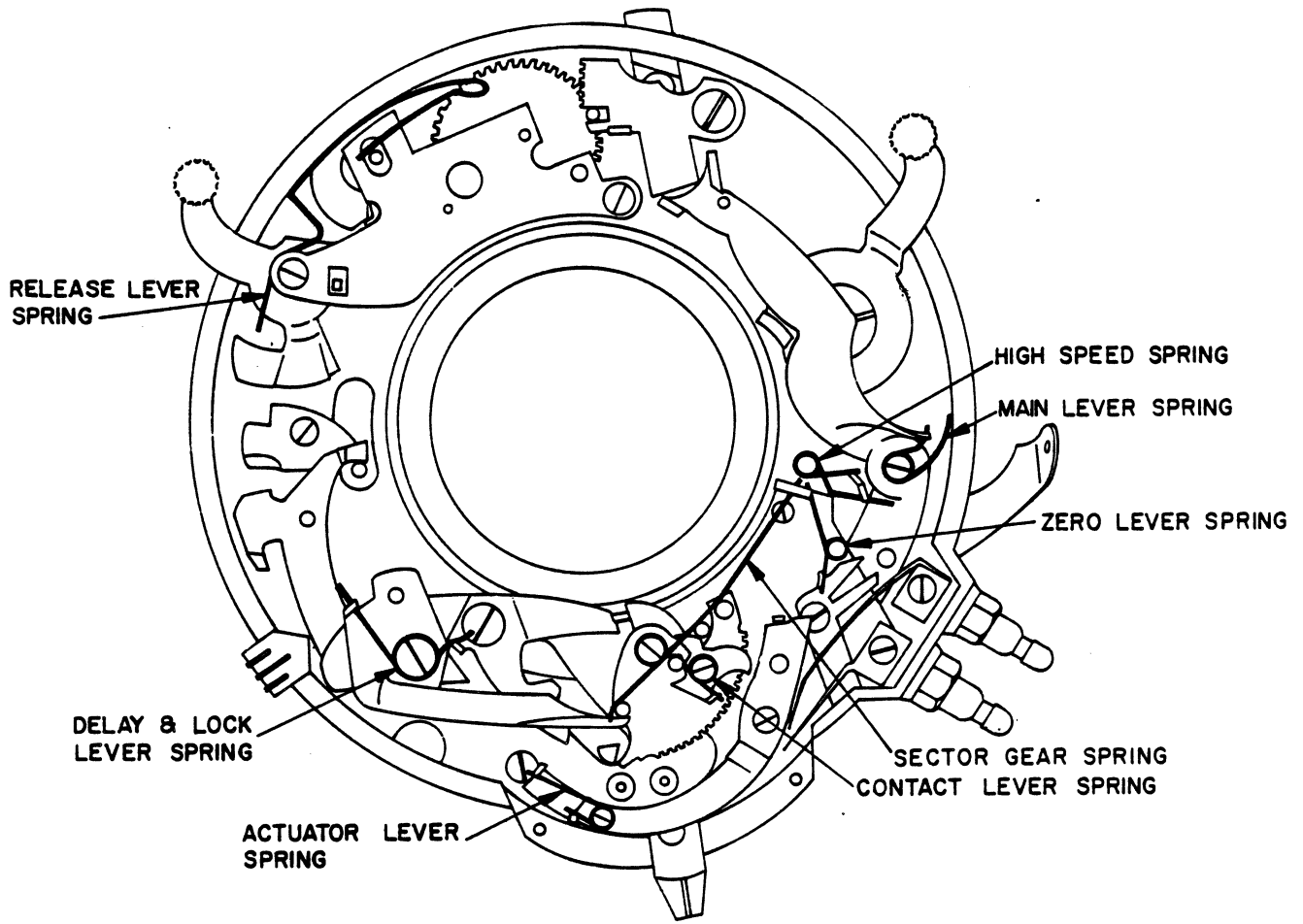

Figure 20. NO. 1 SHUTTER, SPRING POSITIONS

GRAPHHEX SHUTTERS

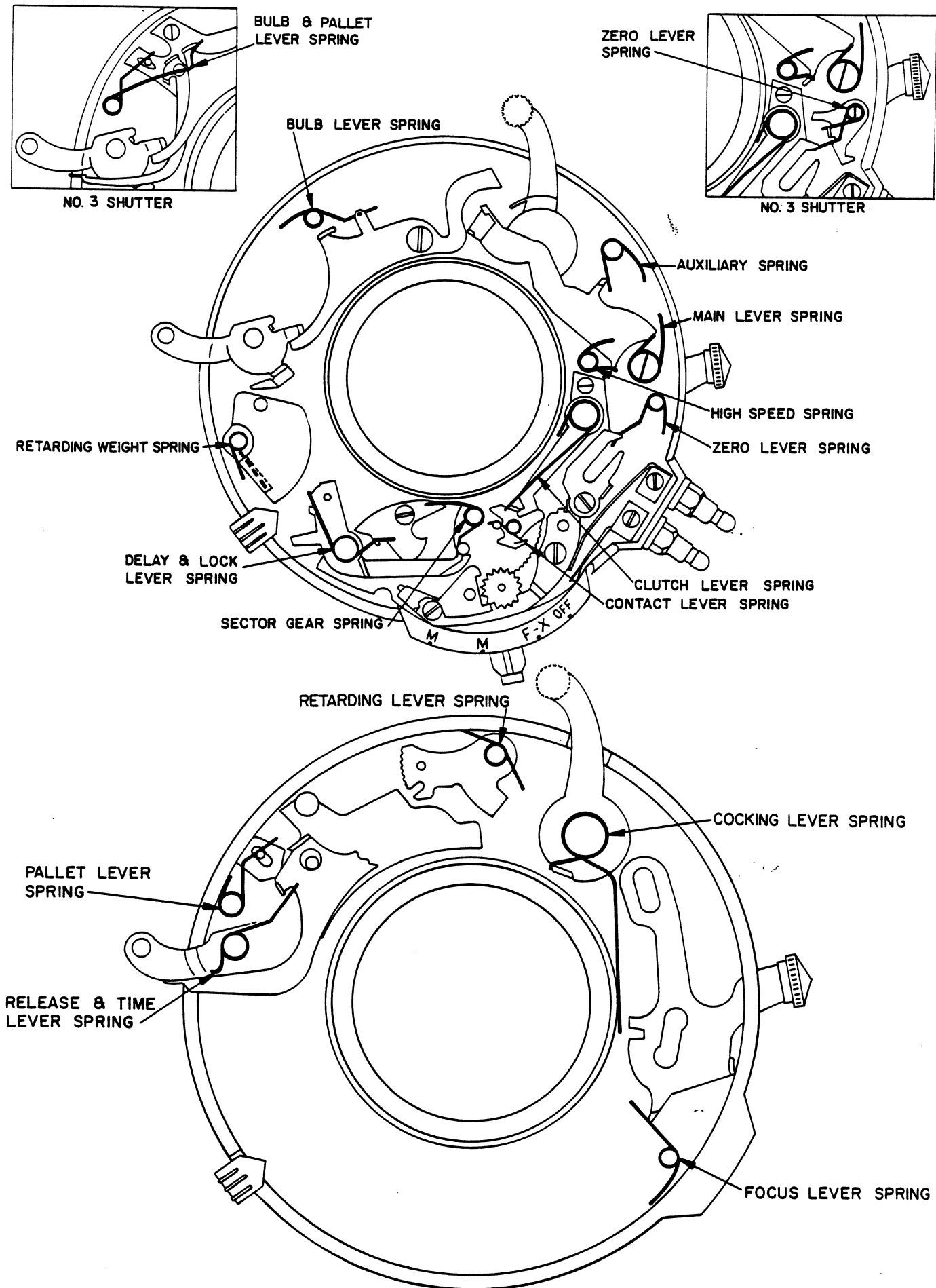

Figure 21. NO. 2 AND 3 SHUTTER, SPRING POSITIONS

12. Repairs - General

When working on the lens and shutter assemblies exercise caution to avoid damage to delicate parts. Do not attempt to force parts together or apart. If parts do not mate properly check the possibility that they do not belong together. Use care when removing parts so that springs under tension do not fly out and get lost. When disassembling the shutter, group associated parts, and arrange the parts in the order in which they were removed. Disassemble the lens and shutter assemblies only as far as it is necessary to reach a defective part. Follow the complete disassembly given in the following paragraphs when it is necessary to cover complete cleaning (para. 27), lubrication (para. 28) and major overhaul of the lens and shutter assemblies.

13. No. 1 Shutter, Disassembly - Stage 1 (fig. 8)

a. Remove rear and front lens elements (1 and 2), unscrewing each in a counterclockwise direction.

b. Remove two nameplate screws (3), nameplate (4), speed ring (5), speed ring spacer (6) and two nameplate spacer rings (7).

c. Remove three (long) front case screws (8), one (short) front case screw (9), and front case and cam assembly (10). If it is necessary to disassemble front case and cam assembly, unscrew cam screw (11) securing the speed cam assembly (12) to front case (13).

d. From back of the shutter, unscrew locating pin (14).

14. No. 1 Shutter, Disassembly - Stage 2 (fig. 9)

a. Remove two contact screws (1), contact assembly "A" (2) and contact assembly "B" (3).

b. Unscrew two prongs (4). Remove two prong screws (5), insulator block (6), and two prong insulators (7).

c. Remove synchronizer assembly (9) as follows:

(1) Unhook zero lever spring from zero lever to relieve spring tension.

(2) Set synchronizer indicator lever to "off" position, and remove two synchronizer screws (8) from their mounting holes "A" and "B".

(3) Set synchronizer indicator lever to black "M" position. Back-off zero lever screw enough to permit shifting the zero lever so that one synchronizer support screw can be removed from its mounting hole "C". Carefully remove synchronizer assembly (9).

15. No. 1 Shutter, Disassembly - Stage 3 (fig. 10)

a. Unhook delay and lock lever spring (1) from delay lever (3) and remove spring. Remove delay

lever screw (2) and delay lever.

b. Remove two millisecond scale screws (4) and millisecond scale (5).

c. Remove synchronizer escapement wheel assembly (6), and synchronizer pallet (7).

d. Unhook actuator lever spring (9). Remove actuator lever screw (8) and actuator pivot screw (10) with actuator lever spring attached. Remove actuator lever (11).

e. Remove zero lever screw (12), zero lever (13) and zero lever spring (14).

f. Remove lock lever screw (15) and lock lever (16).

g. Remove sector gear spring (17) from sector gear screw (21).

h. No further disassembly of the synchronizer sub-assembly (18) should be performed except for replacement of contact lever spring (19), contact lever screw (20) and sector gear screw (21).

16. No. 1 Shutter, Disassembly - Stage 4 (fig. 11)

a. Remove bulb and time lever screw (1), bulb lever (2) and time lever (3).

b. Unhook high speed spring (4) from main lever assembly (7) and remove spring.

c. Remove main lever screw (5), main lever spring (6) and main lever assembly (7).

d. Remove cocking lever screw (9) with cocking lever spring (8) attached. Remove cocking lever assembly (10), and cocking lever washer (11).

e. Unscrew focus lever button (12). Unhook focus lever spring (14) from focus lever (16). Remove focus lever spring screw (13) and focus lever spring. Remove two focus lever screws (15) and focus lever.

17. No. 1 Shutter, Disassembly - Stage 5 (fig. 12)

a. Remove blade lever spring screw (1) and blade lever spring (2). Remove blade lever screw (3), blade lever (4), and shutter blade stud washer (5).

b. Remove retarding lever screw (6), and retarding lever assembly (7) with retarding lever spring (8) attached. Remove release lever screw (9), and bulb and time lever spring (10). Remove retarding device cover screw (11) and retarding device cover (12).

c. Remove release lever spring (13), release lever assembly (14), retarding wheel assembly (15), escapement wheel assembly (16), and pallet (17).

d. Remove cable release lever screw (18), and cable release lever (19).

GRAPHEX SHUTTERS

e. Remove pallet lever screw (20), and pallet lever assembly (21).

f. Remove cable release socket screw (22) and cable release socket (23).

g. Remove back case screw (24), three outer support plate screws (25), three inner support plate screws (26), and support plate assembly (27).

18. No. 1 Shutter, Disassembly - Stage 6 (fig. 13)

a. Remove three shutter blade assemblies (1) and revolving ring assembly (2).

b. Carefully examine diaphragm plate and leaf assembly (5) and inside of shutter case (8) for previously scribed matchmarks. If none are present scribe a set of matchmarks very lightly on these parts to aid in reassembly.

c. Remove diaphragm stop screw (3), three diaphragm plate screws (4), and diaphragm plate and leaf assembly (5).

d. Remove six diaphragm leaves (6) only if they need replacing.

e. Remove diaphragm indicator ring (7) from shutter case (8).

19. No. 2 and 3 Shutter, Disassembly - Stage 1 (fig. 14)

a. Release shutter.

b. Remove rear and front lens elements (1 and 2), unscrewing each in a counterclockwise direction.

c. Remove nameplate locking ring (3) by unscrewing ring in a counterclockwise direction. Remove nameplate (4) and speed cam assembly (5).

d. Remove high speed spring (6).

e. From side of the shutter case, remove dust shield screw (7) and dust shield (8).

f. From back of shutter, unscrew locating pin (9).

20. No. 2 and 3 Shutter, Disassembly - Stage 2 (fig. 15)

a. Remove two contact screws (1), contact assembly "A" (2) and contact assembly "B" (3).

b. Unscrew two prongs (4). Remove two prong screws (5) by placing their ends against a flat surface and forcing them out through holes in shutter case. Remove insulator block (6) and two prong insulators (7).

c. Unhook end of delay and lock lever spring (8) from delay lever (10). Remove delay lever screw (9) with delay and lock lever spring attached. Remove delay lever (10).

d. Set synchronizer indicator lever to black "M". Unhook clutch lever spring from clutch lever. Remove three synchronizer support screws (11) and carefully remove synchronizer assembly (12).

21. No. 2 and 3 Shutter, Disassembly - Stage 3 (fig. 16)

a. Remove clutch lever screw (2) with clutch lever spring (1) attached. Remove clutch lever (3).

b. Remove sector gear spring (4) from sector gear screw (18). Remove synchronizer pallet (5) and synchronizer escapement wheel assembly (6).

c. Remove two actuator lever screws (7) and actuator lever (8). Remove zero lever screw (9) and zero lever assembly (10). Remove lock lever screw (11) and lock lever (12).

d. Remove two millisecond scale screws (13) and millisecond scale (14) from synchronizer subassembly (15).

e. No further disassembly of the synchronizer subassembly (15) should be performed except for replacement of contact lever spring (16), contact lever screw (17) and sector gear screw (18).

22. No. 2 and 3 Shutter, Disassembly - Stage 4 (fig. 18)

a. Remove retarding weight screw (2) with retarding weight spring (1) attached. Remove retarding weight assembly (3).

b. The following steps are applicable to the shutters noted:

(1) No. 2 Shutter:

Unhook bulb lever spring from the bulb lever (6).

(2) No. 3 Shutter:

Unhook bulb and pallet lever spring (4) from bulb lever (6) and remove spring.

c. Unhook release and time lever spring (25) from time lever (7). Unscrew bulb and time lever screw (5). Remove bulb lever (6) and time lever (7).

d. The following steps are applicable to the shutters noted:

(1) No. 2 Shutter:

Remove zero lever spring screw (9) with zero lever spring (8) attached.

(2) No. 3 Shutter:

Remove stop lever screw (10) with zero lever spring attached. Remove stop lever (11).

e. Remove auxiliary spring (12), main lever screw

(13), main lever spring (14) and main lever assembly (15).

f. Remove cocking lever screw (17) with cocking lever spring (16) attached, cocking lever assembly (18) and cocking lever washer (19).

g. Unscrew focus lever button (20) and remove focus lever spring (21).

h. The following steps are applicable to the shutters noted:

(1) No. 2 Shutter:

Remove one focus lever screw (22), and focus lever (23).

(2) No. 3 Shutter:

Remove two focus lever screws (22), and focus lever (23).

i. Remove release lever screw (24), release and time lever spring (25) and, release lever assembly (26).

23. No. 2 and 3 Shutter, Disassembly - Stage 5 (fig. 18)

a. Remove blade lever spring screw (1) and blade lever spring (2). Remove blade lever screw (3) and blade lever (4).

b. On the No. 2 Shutter, remove pallet lever spring (5), and bulb lever spring (6).

c. Remove one (large) retarding device cover screw (7), two (small) retarding device cover screws (8) and retarding device cover (9).

d. Remove retarding lever screw (10), and retarding lever assembly (11) with retarding lever spring (12) attached. Remove retarding wheel assembly (13), escapement wheel assembly (14), center wheel assembly (15), pallet (16), pallet lever assembly (17), and cable release lever assembly (18).

e. Remove cable release socket screw (19) and cable release socket (20).

f. Remove three (long) support plate screws (21), four (short) support plate screws (22) and support plate assembly (23).

24. No. 2 and 3 Shutter, Disassembly - Stage 6 (fig. 19)

a. Remove blade separator washer (1) five shutter blade assemblies (2) and revolving ring assembly (3).

b. Remove three diaphragm plate screws (4), and diaphragm plate and leaf assembly (5).

c. Remove ten diaphragm leaves (6) only if the need replacing.

d. Remove diaphragm indicator ring (7) from shutter case (8).

25. Cleaning Disassembled Parts

Clean disassembled parts of lens and shutter assemblies as follows:

a. Clean unpainted metal mechanical parts with chlorothene. Dry the cleaned parts thoroughly; use a clean lint-free cloth or a gentle blast of compressed air. When cleaning parts of shutter assembly, such as levers and gears, use a small brush moistened with cleaning compound to clean parts thoroughly.

b. Wipe painted metal parts and non-metallic parts with a soft lint-free cloth moistened with cleaning compound. Thoroughly dry cleaned parts with a clean, dry, lint-free cloth.

c. Give special attention to contacting surfaces of contact assemblies (2 and 3, fig. 18 or 2 and 3, fig. 25). If surfaces are tarnished polish them until they are clean and bright.

d. Inspect and replace parts that show excessive wear or are damaged.

26. Lubrication - General

All parts of the shutters that require lubrication are indicated on exploded view illustrations and specified in paragraphs concerning shutter reassembly instructions. Where Lubricating Oil, General Purpose (LO) is specified, apply one drop with a small wire and wipe the oiled surface with a lint-free cloth. Use a small brush to apply Grease, Aircraft and Instrument (GL).

CAUTION

Excessive or incorrect lubrication, or use of lubricants other than those specified, could cause malfunction within the shutter mechanism. Avoid getting any lubricant on lenses, shutter blades, or diaphragm leaves.

27. No. 1 Shutter, Reassembly - Stage 1 (fig. 13)

a. Apply grease (GL) to underside raised surfaces of diaphragm indicator ring (7), before reassembling into the shutter case (8). Do not allow grease to contact recessed surface. Move indicator ring back and forth to distribute grease evenly. Move diaphragm indicator ring to its extreme clockwise position.

CAUTION

Be sure there is no grease on upper surface of diaphragm indicator ring.

b. If diaphragm plate and leaf assembly (5) has been previously disassembled, reassemble by staking six diaphragm leaves (6) one by one in a counterclock-

wise direction. The starting point is not critical. Each successive leaf will lie on top of the preceding one.

c. Before reassembling diaphragm plate and leaf assembly (5) to shutter case, insert a pencil in diaphragm opening and with a circular motion carefully move diaphragm leaves until they open to full aperture. Position guide hole of each diaphragm leaf for mating with slots in diaphragm indicator ring by inserting an awl into the pivot hole of each diaphragm leaf. Insert diaphragm plate and leaf assembly into shutter case with diaphragm leaves facing down. Locate matchmarks scribed on diaphragm plate and leaf assembly and on the inside of the shutter case (8). When the matchmarks are aligned, apply slight pressure to diaphragm plate and leaf assembly and slowly move diaphragm indicator ring (7) counterclockwise until it clicks into engagement with diaphragm leaves. Check diaphragm leaves for smooth closing and opening action before assembling three diaphragm plate screws (4) into the countersunk holes.

d. Thread diaphragm stop screw (3) into rear of shutter.

e. Open diaphragm to its widest aperture. Assemble revolving ring assembly (2) in track on diaphragm plate and leaf assembly (5) so that long stud on revolving ring locates opposite slot closest to the pointer on the diaphragm indicator ring. Using tweezers, lay three shutter blade assemblies (1) successively into position, starting with first blade assembly on the long stud on revolving ring assembly and working clockwise. Be sure that stud on each blade assembly seats into a slot in the diaphragm plate and leaf assembly. Keep shutter blades in the open position.

28. No. 1 Shutter, Reassembly - Stage 2 (fig. 12)

a. Locate support plate assembly (27) over shutter leaves so that long stud on the revolving ring assembly, and countersunk holes in support plate assembly are aligned with holes in diaphragm plate and leaf assembly. Secure support plate assembly using three short support plate screws (26) through the inner holes and three long support plate screws (25) through the outer holes. Seat all screws below the surface of the support plate assembly.

b. Screw back case screw (24) into rear of the shutter.

c. Insert cable release socket (23) and secure with cable release socket screw (22).

d. Oil (LO) stud on pallet lever assembly (21); position pallet lever assembly on support plate, and secure with pallet lever screw (20).

e. Position cable release lever (19) on support plate, and secure with cable release lever screw (18).

f. Place pallet (17) on the stud of pallet lever

assembly (21).

g. Oil escapement wheel assembly (16) by touching each end of pinion to a felt pad moistened with oil (LO). Insert short end of pinion into its mounting hole. Oil escapement wheel assembly (15) in the same manner and insert into its mounting hole with the pin facing up.

h. Lightly grease (GL) inside bearing surface of release lever assembly (14) and place it on its mounting stud. Assemble release lever spring (13) on release lever assembly with short end down and between bearing and handle of the release lever assembly. Position retarding device cover (12) over gear train, and while holding in place, wind long end of release lever spring clockwise and position it between shutter cam and pallet stud. (Refer to fig. 30.) Still holding retarding device cover in place, assemble retarding device cover screw (11). Lay bulb and time lever spring (10), long end down, on retarding device cover and secure with release lever screw (9). Hook-up of spring will be done in stage 3. Hold pallet out of engagement and spin retarding wheel assembly (15) to check gear train for smooth operation.

i. Assemble retarding lever spring (8) on retarding lever assembly (7) with long end of the spring facing down and located between the bearing and lug. Apply oil (LO) to inside bearing surface. Rotate retarding wheel assembly so that its pin is located opposite the cable release socket screw. Position retarding lever assembly (7) on its mounting stud so that short end of retarding lever spring rests against the retarding lever lug and long end locates against the retarding device cover post. (Refer to fig. 31.) Rotate retarding lever assembly clockwise and engage pin on retarding wheel assembly into slot on retarding lever assembly. Secure retarding lever with retarding lever screw (6). Check gear train for smooth operation.

J. Place shutter blade stud washer (5) on long stud of revolving ring assembly.

k. Assemble blade lever (4) so that its slot engages the long stud on revolving ring assembly, and secure with blade lever screw (3). Position blade lever spring and secure with blade lever spring screw (1). Do not bend spring when tightening screw. Check shutter blade operation by pushing blade lever with a screwdriver to check spring tension. Proper tension will cause shutter blades to snap open.

29. No. 1 Shutter, Reassembly - Stage 3 (fig. 11)

a. Insert focus lever (16) through slot in shutter case. Engage short stud of revolving ring assembly with slot in focus lever and secure with two focus lever screws (15).

b. Apply grease (GL) to formed end of focus lever spring (14). Assemble focus lever spring with straight end down and secure with focus lever spring screw (13). Draw formed end of spring counterclockwise and hook into notch in focus lever. (Refer to

fig. 20.) Screw focus lever button (12) into focus lever.

c. Position cocking lever washer (11) over hole in support plate. Apply a light film of grease (GL) to bottom surface of cocking lever assembly (10), position over washer and secure with cocking lever screw (9). Center washer when tightening screw so that setting lever will rotate freely when screw is tightened. Assemble cocking lever spring (8) over cocking lever screw with long end down and against the high speed spring mounting stud. Wind short end of the spring clockwise and hook it to the lug on the cocking lever. (Refer to fig. 20.)

d. Assemble main lever assembly (7) on its mounting stud. Assemble main lever spring (6) on pivot of the main lever assembly with short end down and located in outside notch on the main lever assembly. Wind spring one quarter turn counterclockwise and locate long end of spring into slot in shutter case. (Refer to fig. 20.) Secure main lever assembly with main lever screw (5). Apply a light film of grease (GL) to surface of the main lever assembly on which the cocking lever assembly travels. Grease (GL) long end of the high speed spring (4) and position it on its stud, short end down. Locate short end of spring in the lower notch on main lever lug, and wind long end clockwise, locating it into upper notch on the main lever lug. (Refer to fig. 20.)

e. Test shutter action at this time as follows:

- (1) With shutter released, hold retarding lever assembly up against the cable release socket.
- (2) Clearance between small lug on the main lever assembly and face of retarding lever assembly at position "A" (Refer to fig. 22C.) should be between .005 inch and .010 inch.
- (3) Still holding retarding lever assembly against cable release socket, move cocking lever slowly until main lever is at position "B". (Refer to fig. 22B.) At this point the main lever should just clear the face of the retarding lever.
- (4) Cock and release the shutter, observing full retarding action. The shutter blades should remain open for one second.
- (5) With the shutter released, a slight clearance should be maintained between the blade lever hook of the main lever assembly and the revolving ring assembly stud. File the hook slightly, if necessary. (Refer to fig. 22A.)
- (6) The releasing arm of the main lever assembly should just clear the blade lever and hook solidly on the releasing hook of the release lever assembly when the shutter is cocked. If the releasing arm is too high, bend the main lever at point B to achieve correct engagement with the releasing hook. (Refer to fig. 22A.)

f. Assemble time lever (3) and bulb lever (2) over hole in retarding device cover, and secure in place with bulb and time lever screw (1).

g. Locate long end of the bulb and time lever spring in notch on time lever lug; wind short end of spring clockwise and locate in notch on bulb lever lug. (Refer to fig. 20.)

30. No. 1 Shutter, Reassembly - Stage 4 (fig. 10)

a. Replace sector gear screw (21) if previously removed. Apply oil (LO) in the recess in the sector gear bearing.

b. Replace contact lever screw (20) and contact lever spring (19), if previously removed from synchronizer subassembly (18). The contact lever spring is assembled over the screw with short end of spring down. Hook the short end of spring on lug on contact lever and wind long end of spring clockwise to rest against small stud on sector gear. (Refer to fig. 20.)

c. Assemble sector gear spring (17) to sector gear screw with the long end down and inserted through hole in lug of the synchronizer subassembly. Rotate sector gear to its farthest counterclockwise position and wind short end of the sector gear spring clockwise; position it behind large stud on sector gear. (Refer to fig. 20.)

d. Apply grease (GL) to friction surfaces of lock lever (16) and secure with lock lever screw (15).

e. Assemble zero lever spring (14) to its mounting stud with short end of spring down. Position zero lever (13) and secure with zero lever screw (12).

f. Apply grease (GL) to friction surfaces of actuator pivot screw (10) and actuator lever screw (8). Assemble actuator lever spring (9) over the head of the actuator pivot screw, with short end down and located in notch of actuator lug. Wind long end of spring counterclockwise and locate long end in notch of lug on the synchronizer subassembly. (Refer to fig. 20.)

g. Oil (LO) bearing holes of synchronizer pallet (7) and synchronizer escapement wheel assembly (6); assemble each to their respective mounting studs.

h. Assemble millisecond scale (5) and secure with two millisecond scale screws (4).

i. Apply grease (GL) to underside friction surface and top recess surface of delay lever (3). Assemble delay lever with delay lever screw (2). Assemble delay lever and lock lever spring (1) over delay lever screw with short end of spring down and located in notch of the lock lever lug. Wind long end of spring clockwise and locate in notch of delay lever lug. (Refer to fig. 20.)

GRAPHEX SHUTTER

31. No. 1 Shutter, Reassembly - Stage 5 (fig. 9)

- a. Set the synchronizer indicator lever to "off" position.
- b. Place synchronizer assembly (9) into the shutter so that stud on the main lever locates in slot in the synchronizer support plate, and synchronizer assembly locates on its mounting studs. Secure synchronizer assembly with three synchronizer support screws (8).
- c. Set synchronizer indicator lever to black "M" position and locate long end of zero lever spring in notch of lug on synchronizer assembly. Wind short end of spring counterclockwise and locate short end of spring behind lug on the zero lever. (Refer to fig. 20.)
- d. Insert two prong insulators (7) into shutter case. Assemble insulator block (6). Insert two prong screws (5) through the insulator block, and assemble two prongs (4), making sure head of each prong screw locates flat in shutter case.
- e. Locate contact assembly "B" (3) over left prong screw and secure in place with contact screw (1). Contact assembly "B" should lie tight against shutter case. Locate contact assembly "A" (2) over right prong screw and secure in place with contact screw (1). Contacts should have full surface contact when closed. If necessary, bend contact assembly "A" so that its insulator bears lightly against the actuator lever. When shutter is operated with the contact lever set on black "M", red "M" or "F-X" position good electrical contact is necessary.

32. No. 1 Shutter, Reassembly - Stage 6 (fig. 8)

- a. Screw locating pin (14) into rear of shutter case. If front case and cam assembly (10) was disassembled, grease (GL) top surface of the speed cam assembly (12) and inside edges of cam slot. Assemble speed cam assembly (12) to front case (13) with cam screw (11).
- b. Assemble front case and cam assembly (10) to shutter case with one short front case screw (9) and three long front case screws (8). To orient the front case and cam assembly for installation, line up the two machined indents located on the outer edge of front case with release lever cutout in shutter case. Before tightening front case screws, rotate speed cam assembly back and forth to insure that bulb lever, time lever, and pallet lever stud are not jammed beneath it.
- c. Grease (GL) both sides of speed ring spacer (6) and place it on the speed ring assembly (5). Assemble the speed ring assembly with spacer attached, so that stud on speed ring engages slot of the speed cam assembly.
- d. Rotate speed ring assembly fully counterclockwise. Position two nameplate spacer rings (7) and nameplate (4) so that speed indicator mark on nameplate aligns with the "T" on speed ring. Secure nameplate spacer rings and nameplate with two nameplate screws (3).
- f. Screw front and rear lens elements (2 and 1) clockwise into the shutter.
- g. Test shutter as per Section IV.

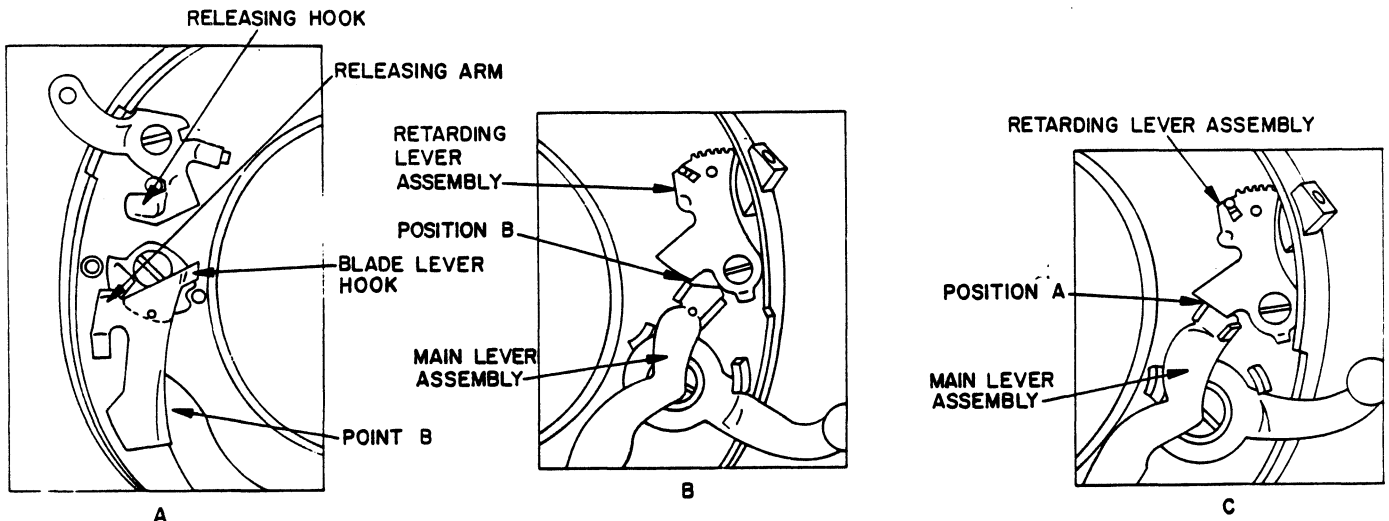

Figure 22. NO. 1, 2, AND 3, SHUTTER, MAIN LEVER ALIGNMENT

33. No. 2 and 3 Shutter, Reassembly - Stage 1
(fig. 19)

a. Apply a thin film of grease (GL) to underside raised portion of diaphragm indicator ring (7), before reassembling into the shutter case (8). Do not allow grease to contact recessed surface. Move indicator ring back and forth to distribute grease evenly. Move diaphragm indicator ring to its extreme clockwise position.

CAUTION

Be sure there is no grease on top surface of diaphragm indicator ring.

b. If diaphragm plate and leaf assembly (5) has been previously disassembled, reassemble by staking ten diaphragm leaves (6), one by one, in a counterclockwise direction. The starting point is not critical. Each successive leaf will lie on top of the preceding one.

c. Before reassembling diaphragm plate and leaf assembly (5) into the case subassembly, insert a pencil in diaphragm opening, and with a circular motion, carefully move diaphragm leaves until they open to full aperture. Position guide hole of each diaphragm leaf for mating with slots in the diaphragm indicator ring by inserting an awl into pivot hole of each diaphragm leaf. Insert the diaphragm plate and leaf assembly into the shutter case with the diaphragm leaves facing down. Orient the diaphragm plate and leaf assembly so that the embossed hole "A" opposite the embossed hole "B" locates over the hole in the shutter case nearest the pointer on the diaphragm indicator ring. Apply slight pressure on diaphragm plate and leaf assembly and slowly move diaphragm indicator ring counterclockwise until it clicks into engagement with the diaphragm leaves. Check diaphragm leaves for smooth closing and opening action before assembling the three diaphragm plate screws (4) into countersunk holes.

d. Open the diaphragm to its widest aperture. Assemble revolving ring assembly (3) in track on the diaphragm plate and leaf assembly so that long stud on revolving ring locates opposite the slot closest to the pointer on the diaphragm indicator ring. Using tweezers, lay five shutter blade assemblies (2) successively into position, starting with the first blade assembly on long stud on the revolving ring assembly and working counterclockwise. Be sure that stud on each blade assembly seats into its slot in the diaphragm plate and leaf assembly. Place blade separator washer (1) on the mounting stud of the last blade assembled. Keep shutter blades in the open position.

34. No. 2 and 3 Shutter, Reassembly - Stage 2
(fig. 18)

a. Locate support plate assembly (23) over shutter leaves so that long stud on revolving ring assembly locates into slot "A" and countersunk holes in support plate assembly are aligned with holes in diaphragm plate and leaf assembly. Secure support

plate assembly with four short support plate screws (22) through the inner holes and three long support plate screws (21) through outer holes. Seat all screws below surface of the support plate assembly (23).

b. Insert cable release socket (20) and secure with cable release socket screw (19).

c. Place cable release lever assembly (18) on its mounting stud. Oil (LO) stud on pallet lever assembly (17). Mount pallet lever assembly on its mounting stud. Place the pallet (16) over stud on pallet lever assembly.

d. Oil center wheel assembly (15) by touching each end of pinion to a felt pad moistened with oil (LO). Insert short end of the pinion into center hole in the support plate assembly (23). Oil the escapement wheel assembly (14) in the same manner and insert into its mounting hole with pinion teeth facing down. Oil retarding wheel assembly (13) in the same manner and insert into its mounting hole with the pin facing up. Align retarding device cover (9) to posts of support plate assembly, being careful not to disturb gear train. Secure retarding device cover in place with large retarding device cover screw (7) in outer hole and two small retarding device cover screws (8) in inner hole. Hold pallet out of engagement and spin retarding wheel assembly to check the gear train for smooth operation.

e. Assemble retarding lever spring (12) on retarding lever assembly (11) with long end of spring facing down and located between bearing and lug. Apply oil (LO) to inside bearing surface of retarding lever assembly. Rotate retarding wheel assembly (13) so that its pin is located opposite the cable release socket screw. Place retarding lever with retarding lever spring attached, over its mounting stud on support plate assembly. Locate short end of retarding lever spring against the inside wall of the shutter case (refer to fig. 21) and engage the pin on the retarding wheel assembly in slot of the retarding lever assembly. Secure retarding lever with retarding lever screw (10). Check gear train for smooth operation.

f. Applicable to the No. 2 Shutter only

(1) Assemble bulb lever spring (6) over retarding device cover screw (8) with long end of spring up. Hook-up of spring will be done in stage 3. Assemble pallet lever spring (5) on its mounting stud with short end of spring up and located in slot in shutter case. Wind long end of spring counterclockwise and locate behind pallet lever stud. (Refer to fig. 21.)

g. Assemble blade lever (4) so that long pin on revolving ring assembly locates in slot on blade lever. Secure blade lever in place with blade lever screw (3). Position blade lever spring (2) with long end of spring located in notch on blade lever. Secure blade lever with blade lever spring screw (1). Be careful not to bend spring when tightening screw. Check

shutter blade operation by pushing blade lever with a screwdriver to check spring tension. Proper tension will cause shutter blades to snap open.

35. No. 2 and 3 Shutter, Reassembly - Stage 3
(fig. 17)

a. Grease (GL) inside bearing surface of release lever assembly (26) and place it on its mounting stud. Assemble release and time lever spring (25) on release lever assembly with short end of spring down and located between bearing and handle of release lever assembly. Wind the long end of release lever spring clockwise and temporarily locate it against the pallet lever stud. Hook-up of spring will be done later in this stage.

b. The following steps are applicable to the shutters noted.

(1) No. 3 Shutter:

Insert focus lever (23) through slot in side of shutter case. Engage short stud on the revolving ring assembly in slot in focus lever and secure with two focus lever screws (22).

(2) No. 2 Shutter:

Assemble focus lever in the same manner as above, except secure the focus lever with one focus lever screw (22).

c. Apply grease (GL) to short end of the focus lever spring (21) and assemble spring, short end down, on its mounting stud. Be sure spring locates under the collar of stud; wind short end of the spring counterclockwise and hook short end in notch on focus lever. (Refer to fig. 21.) Screw focus lever button (20) in focus lever.

d. Position cocking lever washer (19) over hole in support plate assembly. Apply a very light film of grease (GL) on bottom surface of cocking lever assembly (18), position over washer, and secure with cocking lever screw (17). Center washer when tightening screw so that cocking lever will rotate freely when screw is tightened. Assemble cocking lever spring (16) over cocking lever screw with long end down and located against barrel of the support plate. Wind short end of the spring clockwise and hook to cocking lever. (Refer to fig. 21.)

e. Place the main lever assembly (15) on its mounting stud. Assemble main lever spring (14) on pivot of the main lever assembly, with short end down and located in outside notch on the main lever assembly. Wind spring one quarter turn counterclockwise and locate the long end of spring in the slot of the shutter case. (Refer to fig. 21.) Secure main lever assembly with main lever screw (13). Apply a light film of grease (GL) to surface of the main lever assembly on which the cocking lever assembly travels. Grease (GL) short end of auxiliary spring (12) and assemble it on its mounting stud with long end down and located against the shutter case. Wind the short end of spring counterclockwise and locate

it in notch on lug of main lever. (Refer to fig. 21.) Test shutter action at this time as follows:

- (1) With the shutter released, hold retarding lever assembly up against cable release socket.
- (2) Clearance between the small lug on the main lever assembly and face of the retarding lever assembly at position "A" (refer to fig. 22C) should be between .005 and .010 inch.
- (3) Still holding retarding lever assembly against cable release socket, move cocking lever slowly until main lever is at position "B" (refer to fig. 22B) at this point main lever should just clear face of the retarding lever.
- (4) Cock and release shutter, observing for full retarding action. Shutter should remain open for one second.
- (5) With shutter released, a slight clearance should be maintained between blade lever hook of the main lever assembly and the revolving ring assembly stud. (Refer to fig. 22A.) File hook slightly if necessary.
- (6) The releasing arm of main lever assembly should just clear blade lever and hook solidly on releasing hook on the release lever assembly when shutter is cocked. (Refer to fig. 22A.) If releasing arm is too high, bend main lever at point "B" to achieve correct engagement with the releasing hook.

f. The following steps are applicable to the shutters noted.

(1) No. 3 Shutter:

Position stop lever (11) on main lever and secure with stop lever screw (10). Assemble zero lever spring (8) over stop lever screw, locating short end down and against stop lever lug. Hook-up of the zero lever spring will be done in stage 5.

(2) No. 2 Shutter:

Screw zero lever spring screw (9) into main lever. Assemble zero lever spring (8) over zero lever spring screw with short end down and located against shutter case. Hook-up of the zero lever spring will be done in stage 5.

g. Assemble time lever (7) and bulb lever (6) over hole in retarding device cover and secure in place with bulb and time lever screw (5).

h. Wind long end of release and time lever spring (25) clockwise and locate in notch on time lever lug. (Refer to fig. 21.)

i. The following steps are applicable to the shutters noted.

GRAPHEX SHUTTER

(1) No. 3 Shutter:

Assemble bulb and pallet lever spring (4) on its mounting stud, short end down and located against pallet lever stud. Wind long end of spring clockwise and locate it in notch on lug of bulb lever. (Refer to fig. 21.)

(2) No. 2 Shutter:

With the short end of bulb lever spring against wall of shutter case, wind long end clockwise and locate it under lug on the bulb lever. (Refer to fig. 21.)

j. Assemble retarding weight assembly (3) on its mounting stud. Assemble retarding weight spring (1), long end up, on the retarding weight screw. Thread the retarding weight screw partway into retarding weight mounting stud. Locate short end of spring in groove of retarding weight assembly and long end of spring into slot in shutter case. (Refer to fig. 21.) Tighten screw. The weight assembly should move freely.

36. No. 2 and 3 Shutter, Reassembly - Stage 4 (fig. 16)

a. Replace sector gear screw (18) if previously removed. Apply oil (LO) in recess in the sector gear bearing.

b. Replace contact lever screw (17) and contact lever spring (16), if previously removed from synchronizer subassembly (15). The contact lever spring is assembled over the screw with short end of spring down. Hook short end of spring over lug on contact lever and wind long end clockwise to rest against small stud on sector gear. (Refer to fig. 21.)

c. Assemble millisecond scale (14) and secure with two millisecond scale screws (13).

d. Apply grease (GL) to friction surfaces of lock lever (12) and secure with lock lever screw (11).

e. Assemble the zero lever assembly (10) and secure with zero lever screw (9).

f. Apply grease (GL) to friction surfaces of actuator lever (8); assemble actuator lever and secure with two actuator lever screws (7).

g. Oil (LO) bearing holes of synchronizer escapement wheel assembly (6) and synchronizer pallet (5); assemble each to their respective mounting studs.

h. Assemble sector gear spring (4) over sector gear screw (18), long end down. Spring will be positioned in stage 5.

i. Assemble the clutch lever (3) and secure with the clutch lever screw (2). Assemble the clutch lever spring (1) over the clutch lever screw. Hook-up of the clutch lever spring will be done in Stage 5.

37. No. 2 and 3 Shutter, Reassembly - Stage 5 (fig. 15)

a. Set synchronizer indicator lever to black "M" position.

b. Rotate sector gear counterclockwise to clear slot in synchronizer support plate. Slide synchronizer assembly (12) so that stud on main lever locates in slot in synchronizer support plate and synchronizer assembly locates on its mounting studs. Secure synchronizer assembly with three synchronizer support screws (11).

c. Hook long end of the clutch lever spring in notch on clutch lever. (Refer to fig. 21.)

d. Locate the long end of the sector gear spring (4, fig. 16) against barrel of support plate; wind short end of spring clockwise and locate it behind large sector gear stud. (Refer to fig. 21.)

e. The following steps are applicable to the shutters noted.

(1) No. 3 Shutter:

Locate short end of zero lever spring (8, fig. 17) in notch on stop lever; wind long end counterclockwise and locate it in notch on zero lever. (Refer to fig. 21.)

(2) No. 2 Shutter:

With the short end of the zero lever spring (8, fig. 17) located against the shutter case, wind long end of spring counterclockwise and locate it in notch on the zero lever. (Refer to fig. 21.)

f. Apply grease (GL) to underside friction surface and to top recess of delay lever (10); assemble delay lever and secure in place with delay lever screw (9). Assemble delay and lock lever spring (8) over the delay lever screw with short end of spring down. Hook short end of spring on lug of lock lever, wind long end clockwise and locate it against lug on the delay lever. (Refer to fig. 21.)

g. Insert two prong insulators (7) into shutter case. Assemble insulator block (6). Insert two prong screws (5) through insulator block and assemble two prongs (4), making sure head of each contact screw locates flat in shutter case.

h. Locate contact assembly "B" (3) over left prong screw and secure in place with contact screw (1). The contact assembly "B" should lie tight against, and just below, top surface of millisecond scale. Locate the contact assembly "A" (2) over right prong screw and secure in place with contact screw (1). Contacts should have full surface contact when closed. If necessary bend contact assembly "A" so that its insulator bears lightly against the actuator lever. When shutter is operated, good electrical contact between "A" and "B" contact assemblies is necessary when the contact lever is set on the black

"M", red "M" or "F-X" positions.

38. No. 2 and 3 Shutter, Reassembly - Stage 6
(fig. 14)

- a. Screw locating pin (9) into rear of shutter.
- b. Assemble dust shield (8) and secure with dust shield screw (7).
- c. Grease (GL) long end of high speed spring (6) and place it on its mounting stud with short end of spring facing down and located against lug on the main lever. (Refer to fig. 21.)
- d. Rotate diaphragm indicator ring to midposition. Grease (GL) inside edges of cam slots on speed cam assembly (5). Assemble speed cam assembly so that high speed spring mounting stud locates in inner slot. Apply slight pressure and rotate speed cam assembly back and forth until it seats in place.
- e. Apply grease (GL) to back surface of nameplate (4). Assemble nameplate so that the high speed spring mounting stud locates in small hole on nameplate. Assemble and tighten nameplate locking ring (3) by screwing clockwise.

CAUTION

Avoid over-tightening the locking ring to avoid binding components in internal mechanism.

- f. Screw front and rear lens elements (2 and 1) clockwise into the shutter.
- g. Test shutter as per Section IV.

39. Adjusting Shutter Speeds

Incorrect shutter speeds fall into two categories. Speeds may be either fast or slow throughout the full range of settings; or one or more (but less than all) speeds may be fast or slow.

a. The first condition can be corrected by increasing or decreasing tension on the main lever spring (fig. 11) No. 1 Shutter, or (fig. 17) No. 2 and No. 3 shutter.

b. The second condition can be corrected by swaging or filing speed cam assembly (fig. 8) No. 1 Shutter, or (fig. 14) No. 2 and No. 3 Shutter, at its point of contact with the retarding lever assembly (fig. 12) No. 1 Shutter, or (fig. 18) No. 2 and No. 3 Shutter. Swaging will decrease travel of retarding lever assembly and increase shutter speed. To increase a given shutter speed, first determine the point at which the retarding lever contacts the cam face with shutter set at that speed. Place speed cam on an anvil and strike a dull chisel with its end placed 1/32" from that point. Filing will increase travel of retarding lever assembly and decrease shutter speed. File cam face at the point which contacts the retarding lever assembly when shutter is set at speed to be adjusted.

GRAPHEX SHUTTER

Section IV. FINAL TESTING

40. General

Testing procedures are prepared to determine acceptability of the repaired lens and shutter assemblies. These procedures set forth specific requirements that the repaired equipment must meet after repair.

41. Physical Testing of Lens and Shutter Assemblies

Step No.	Test Equipment Control Setting	Equipment Under Test Control Setting	Test Procedure	Performance Standard
1	N/A	Diaphragm setting lever: any position Speed selector ring: all speed positions Sync lever: all positions	Cock and trip shutter	Cocking lever and release lever operate smoothly. Shutter blades open and close.
2	N/A	Diaphragm setting lever: all positions	Move diaphragm setting lever to extreme positions	Operation is smooth
3	N/A	Press focus lever: open position	Cock shutter and move press focus lever to open position	Shutter blades open smoothly and stay open until shutter is tripped, or press focus lever is moved to closed position
4	N/A	Controls at any setting	Attach cable release; cock and trip shutter	The cable release socket accomodates a standard cable release which, when operated, trips the cocked shutter
5	N/A	Controls at any setting	Cock shutter Trip shutter	Observe shutter blades; they remain fully closed Observe shutter blades; they close fully
6	N/A	Speed selector ring: "B" setting	Cock and trip shutter, and hold trip lever down	Shutter blades stay open
7	N/A	Speed selector ring: "T" setting	Cock and trip shutter Retrip shutter	Shutter blades open and remain open Shutter blades close.

42. Shutter Speed Test

a. Test Equipment

- (1) Berkley time interval meter model 7250U
- (2) Light source control and photo tube amplifier

b. Procedure

GRAPHEX SHUTTERS

Step No.	Test Equipment Control Setting	Equipment Under Test Control Setting	Test Procedure	Performance Standard
1	Set the three controls labeled "sync" or "speed" to the "speed" positions. Set all other controls to positions shown in fig. 23. Make all cord connections as shown in fig. 23.	Set diaphragm indicator ring to largest aperture. Position press focus lever to open shutter blades	Place shutter on tester Operate powerstat control knob to point where meter counting lamps start running. Observe microammeter reading. Operate powerstat control knob to point where meter counting lamps stop running. Observe microammeter reading. Average the two readings, multiply by two; operate the powerstat control knob to point where microammeter reading corresponds with that number.	Readings shall be within tolerances as indicated in chart (para. 45).
2	Same as above	Close shutter blades and set shutter to desired speed.	Cock and trip shutter	

43. "M" Synchronization Delay Test

a. Test equipment (fig. 23)

- (1) Berkley time interval meter model 7250U
- (2) Light source control and photo tube amplifier

b. Procedure

Step No.	Test Equipment Control Setting	Equipment Under Test Control Setting	Test Procedures	Performance Standard
1	Set the three controls labeled "sync" or "speed" to the "sync" positions. Set all other controls to positions shown in fig. 23. Make all cord connections as shown.	Set diaphragm indicator ring to largest aperture. Set sync lever to "M" setting to be checked.	Place shutter on tester Repeat test procedures b, c, and d from Step No. 1 on Shutter Speed Test (para. 42)	Reading shall be within tolerances as indicated in chart (para. 46)
2	Same as above	Same as above	Cock and trip shutter	

44. "X" Synchronization Test

a. Test Equipment

"X" sync contact delay tester (fig. 24)

Step No.	Test Equipment Control Setting	Equipment Under Test Control Setting	Test Procedure	Performance Standard
1	Set power switch to "ON" position	Set shutter to highest shutter speed and largest diaphragm opening (cont'd.)	Cock and release shutter	Readings shall be within tolerances as indicated on chart (para. 46)

GRAPHEX SHUTTERS

Step No.	Test Equipment Control Setting	Equipment Under Test Control Setting	Test Procedure	Performance Standard
		Set sync lever to "X". Plug tester cord to shutter prongs.		

45. Operational Ranges of Shutter Speed Settings

Speed Setting	Minimum Milliseconds	Maximum Milliseconds
400	1.75	3.3
200	3.5	6.5
100	8	12
50	16	24
25	32	48
10	80	120
5	160	240
2	400	600
1	800	1200

46. Operational Ranges of Synchronizer Delay Settings

Sync Lever Setting	Minimum Millisecond Delay Time	Maximum Millisecond Delay Time
Black "M"	16	20
Red "M"	8	12
"F-X"	-1	+1

GRAPHEX SHUTTERS

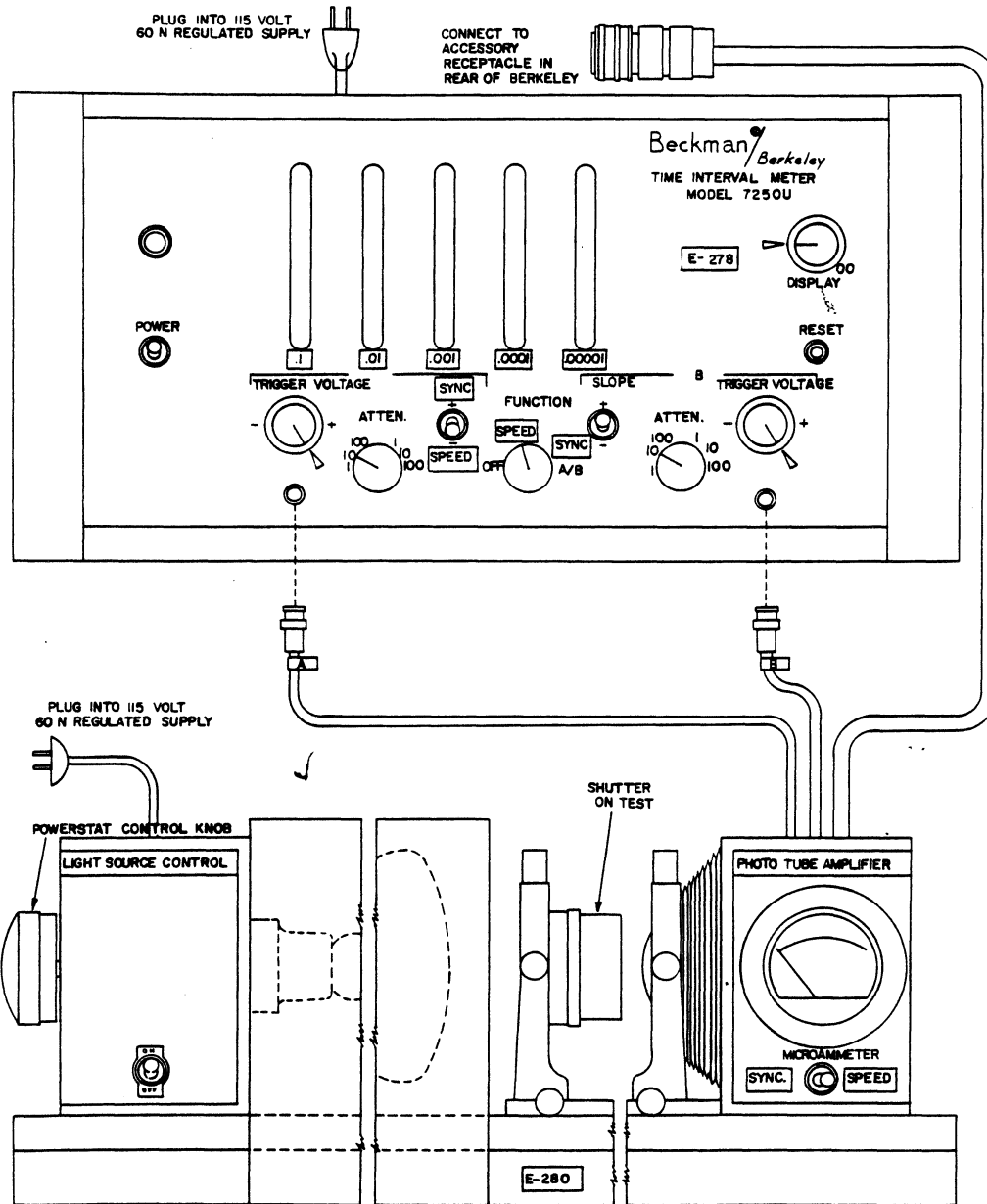

Figure 23. BERKLEY TIME AND INTERVAL METER

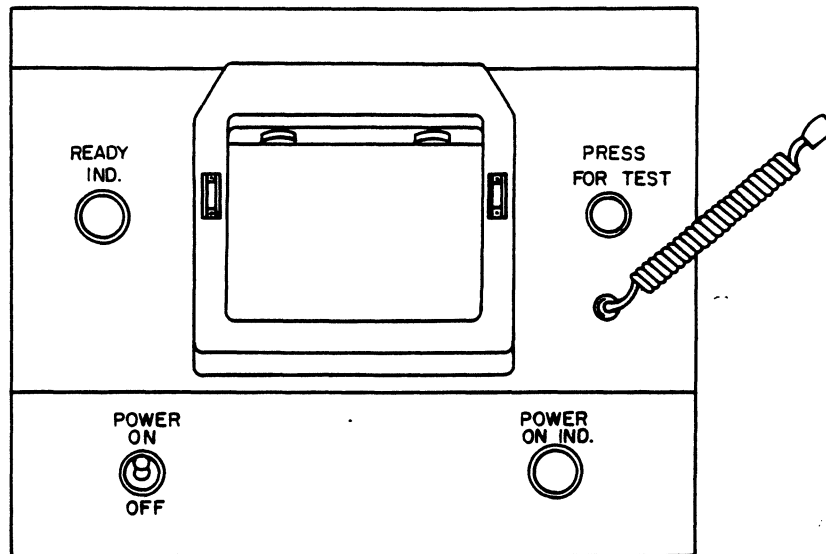

Figure 24. "X" SYNCHRONIZER CONTACT DELAY TESTER