

JANUARY 1966

price \$5.00

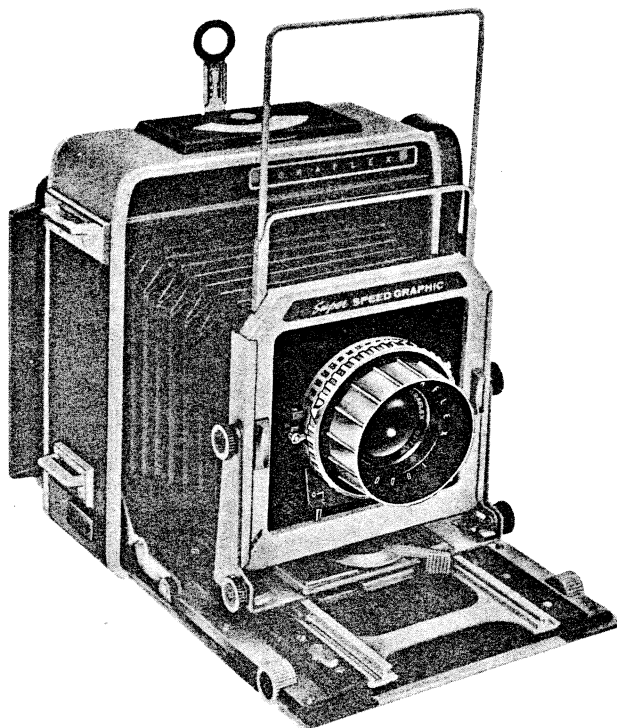
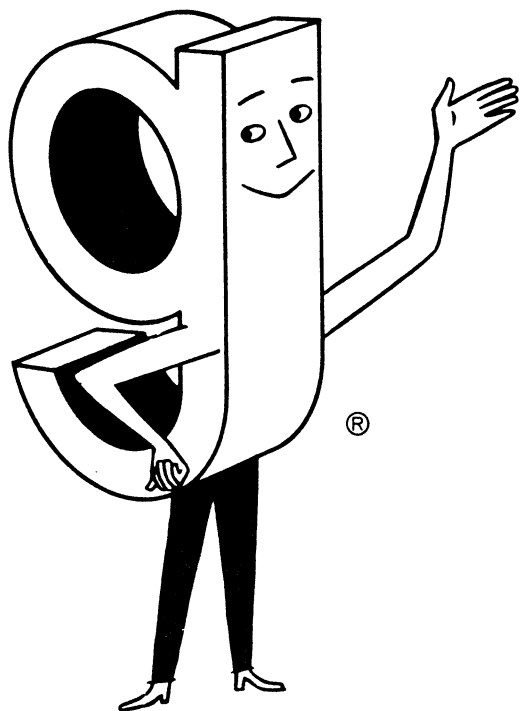

# graflex®

**SERVICE INSTRUCTIONS AND PARTS LIST**

**VOLUME SH 6512**

**GRAFLEX 1000 SHUTTER**

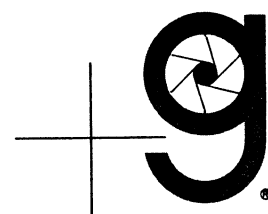



GRAFLEX 1000 SHUTTER

TABLE OF CONTENTS

Paragraph	Title	Page
	Introduction . . . . .	1
A	Recommended Test Equipment and Special Tools . . . . .	2
B	Lubricants, Adhesives and Solvents . . . . .	3
C	Trouble and Remedy . . . . .	4
D	Cleaning . . . . .	6
E	Disassembly - Shutter . . . . .	6
F	Control Plate Complete . . . . .	9
G	Reassembly - Shutter . . . . .	11
H	Malfunctions (Mechanical) . . . . .	16
J	Test . . . . .	17
K	Test Adjustments . . . . .	17
L	Special Repairs . . . . .	18
	Introduction to Parts List . . . . .	18
	Parts List . . . . .	19



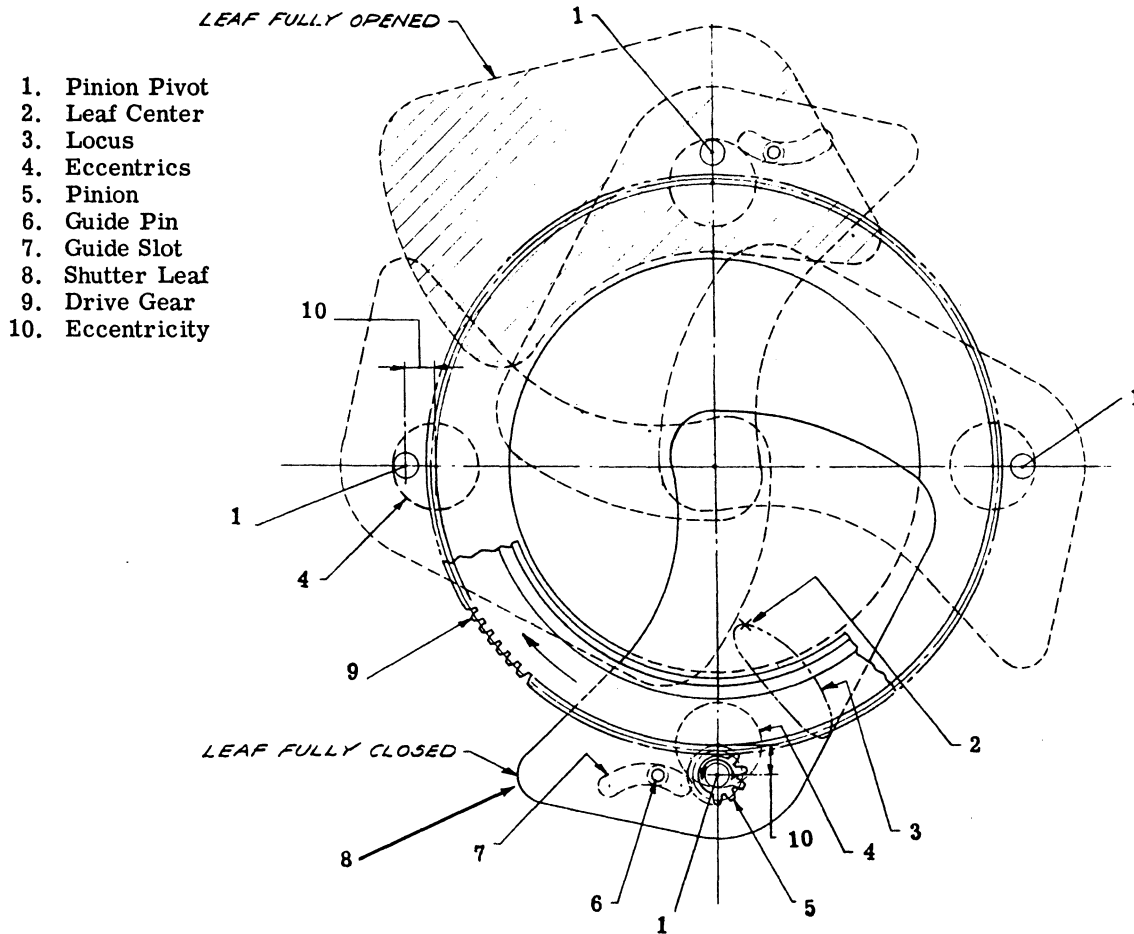

SHUTTER LEAF DRIVE, SCHEMATIC DRAWING

INTRODUCTION

The Graflex 1000 Shutter is a mechanism designed to perform repeatedly within extremely close tolerances. It is more precise than the finest Swiss watch, yet it must be capable of performing under the most adverse conditions. The greatest care has been taken to design and manufacture parts and movements which will meet the customer's needs for precision performance, ruggedness and long life. Unlike a watch whose parts move continuously through gentle arcs, the shutter is required to perform intermittently and to drive all movements instantaneously. It can have no convenient adjustment to "speed it up" or "slow it down" as is found in a watch movement.

The Graflex 1000 Shutter utilizes a totally new concept of shutter operation. The shutter leaves are driven by a master drive gear which rotates in only one direction. Each shutter leaf is eccentrically mounted and guided by a stud operating in a crescent shaped slot. This causes an elliptical motion of the shutter leaves when in operation. The shutter leaves, in following this elliptical path, are not called upon to stop abruptly and reverse direction as in conventional shutters. The drive mechanism travels through 86 degrees before the shutter leaves are

moved enough to admit light thru the aperture. After the aperture is closed, the drive mechanism continues to travel through 64 degrees while coming to a stop. This provides application of a gentle force while the shutter leaves accelerate and a gentle breaking action as the shutter leaves come to rest. Elimination of shock, vibration and shutter bounce means longer shutter life with less maintenance.

Proper timing adjustment can be made only by careful diagnosis at the time the shutter is tested. The shutter can be mechanically perfect, yet fail to meet the tolerances for timing after repair. It must be kept in mind that drag created by the net effect of the weight of the driven parts, tension on springs and friction between moving parts determines whether a shutter will run fast or slow. Much can happen when success or failure to meet performance standards is measured in milliseconds - faster than the human eye can wink.

Close attention should be given to Adjustments After Testing and to Malfunctions. These are the best clues to final acceptance and will minimize the service time required to restore the shutter. Never lose sight of the fact that you are concerned with extremely small measurements. Make all adjustments accordingly.

In this area no service manual can substitute for experience. The manual has been written as a useful guide to help you develop experience with the shutter; to diagnose areas for repair quickly; to identify parts; to guide you through areas not readily apparent from visual examination.

**A. RECOMMENDED TEST EQUIPMENT AND SPECIAL TOOLS**

1. National Camera Motion Analyzer No. E11-29-4 or Berkeley Time Interval Meter, Model 7250U with associated Photo Tube Amplifier and Light Source Control - Used to test shutter speeds and M sync. delay.

2. Sync. Contact Delay Tester - Used to test X sync. delay.

3. 500-Volt Leakage Resistance Tester - Used to check shutter for shorts and leaks.

4. Contact Duration Tester - Used to check contact duration with shutter in camera.

5. Special Tools - See Figures 1 thru 4.

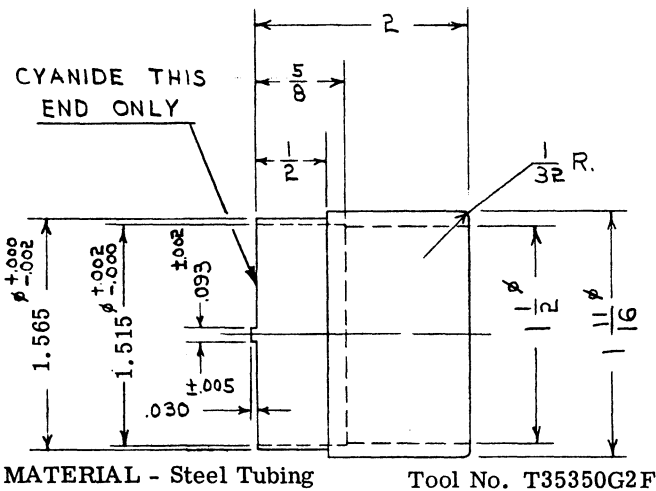

Figure 1. TUBULAR WRENCH  
(use on front lens element)

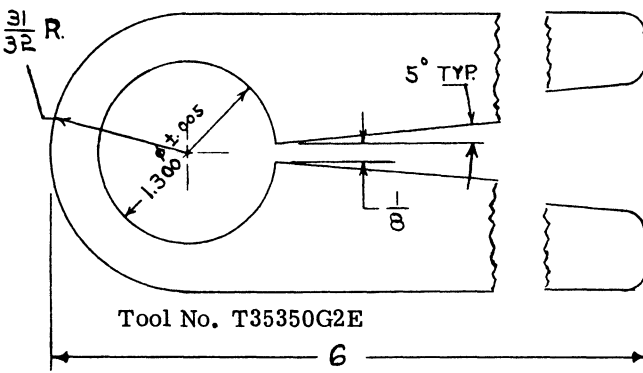
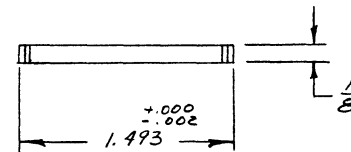
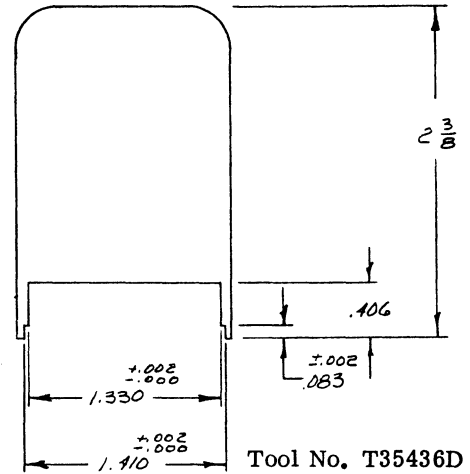

Figure 2. FRICTION WRENCH  
(use on rear lens element)



MATERIAL - Brown & Sharp Flat Ground Stock

Figure 3. SPANNER WRENCH  
(use on retaining nut)

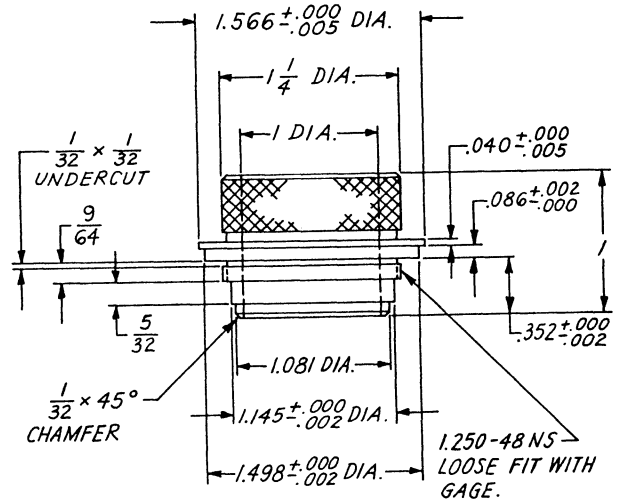

Figure 4. LENS ADAPTER  
(use on shutter during repair)

B. LUBRICANTS, ADHESIVES AND SOLVENTS

quantities. Materials identified with a Graflex part number can be ordered by part number directly from Graflex Inc., Rochester, New York.

As a convenience for service and repair of the 1000 Shutter, materials have been set up in economic

GRAFLEX PART NO.	LUBRICANT	USED ON	REFERENCE
39484P2	Molykote, Type Z	Drive gear assembly (inside diameter and bottom surfaces)	5, Figure 13
38484P8	GXS 7.524	Diaphragm pivot plate (inside diameter)	28, Figure 6
		Steel ball (all surfaces)	16, Figure 8
		Diaphragm gear (all surfaces)	8, Figure 10
		Brake pinion cam (all surfaces)	58d, Figure 5
		Trip latch assembly (contact area at tip)	Figure 13
		Drive springs (all surfaces)	14, Figure 14
		Winding gear (inside diameter and top surfaces)	15, Figure 14
		Winding gear knob assembly (bearing surfaces)	1, Figure 18
		Timing cam (detents)	11, Figure 16
		Cam stop (periphery)	10, Figure 16
		Winding pinions (bearing surfaces)	4, Figure 16
38484P9	Anderol L-401-D	Shutter leaf accentrics (all surfaces)	19, Figure 7
		Gear trains (posts on control plate)	Figure 5
GRAFLEX PART NO.	SEALANT OR ADHESIVE	USED ON	REFERENCE
39490P2	Glyptal #1276	Screws (threads)	15, Figure 10
		Screws (threads)	2, Figure 17
		Rear lens element (threads)	
39491P5	Loctite, Grade A	Screws (securing contact assembly) Model 2B only	8, Figure 25
39491P4	Loctite, Grade H	Screws (threads)	7, Figure 13
		Screws (threads)	56, Figure 5
GRAFLEX PART NO.	SOLVENT	USED ON	REFERENCE
---	Chlorothene	All metal parts	---
39490P3	Glyptal thinner No. 1511 M	---	---

## C. TROUBLE AND REMEDY

Many of the troubles encountered by the repairman will be obvious. Others will not be readily apparent.

The following table lists the trouble, cause and remedy for most shutter failure. Disassemble only as needed to make the repair. Refer to para F and G as a guide when making repairs.

TROUBLE	CAUSE	REMEDY
Shutter leaves tangle	Damaged tooth on shutter leaf eccentric (19, Figure 7)	Replace eccentric
	Loose pin on shutter leaf plate assembly (24, Figure 7)	Replace plate assembly
Shutter leaves fail to close when set on a given speed	Damaged tooth on a timing gear in 1st, 2nd, or 3rd timer gear train (Figure 13)	Replace timing gear
	Damaged tooth or broken post on timing dog assembly (Figure 13)	Replace timing dog
Shutter leaves open after completion of trip cycle	Damaged drive gear assembly (5, Figure 13)	Replace
	Cam brake (Figure 13) travel too long	Remove control plate;swedge elongated slot to shorten travel
	Tip of cam brake (Figure 13) worn	Remove control plate and replace cam brake (para L)
Shutter jammed	Damaged gear train (Figure 13)	Replace damaged component
	Broken drive spring (14, Figure 14)	Replace (use same color - see parts list)
	Weak drive spring (14, Figure 14)	Replace (use same color - see parts list)
	Loose post on control plate assembly (58, Figure 5)	Replace control plate assembly
	Broken post on winding gear assembly (15, Figure 14)	Replace winding gear assembly
	Broken post on drive gear assembly (5, Figure 13)	Replace drive gear assembly
M sync too fast	Worn pallet on sync. train (Figure 13)	Replace
	Worn trip latch assembly (Figure 13)	Replace
	Worn M sync contact (Figure 13)	Replace (see para L)
	Bent M sync. contact (Figure 13)	Adjust (see para K)
	Weak synchronizer lever spring (7, Figure 16)	Replace



TROUBLE	CAUSE	REMEDY
M sync too slow	Dirty M sync train (Figure 13)  Damaged M sync train (Figure 13)	Remove control plate, clean and lubricate (see para F)  Replace damaged component
No contact on M or X sync	Broken contact assembly (Figure 13)  Open circuit	Replace (See para L)  Check continuity and make necessary adjustments or repair
Diaphragm leaf out of position	Broken post on diaphragm leaf assembly (26, Figure 6)	Replace diaphragm leaf assembly
Shutter speeds slow	Damaged gear train (Figure 13)  Dirty gear train  Weak timer springs (3, 3a, or 3b, Figure 13)  Weak drive spring (14, Figure 14)	Replace damaged components  Remove control plate-clean and lubricate (see para F)  Replace  Replace (use same color - see parts list)
Shutter speeds fast	Worn gear train on control plate (Figure 13)	Replace worn component
Shutter winds through	Broken or disengaged trip spring (1, Figure 13)  Worn trip latch assembly (Figure 13)  Levers (8, 9, Figure 12) hung up  Trip link assembly (11, Figure 10) not adjusted properly (Model 2A only)	Replace or reengage trip spring.  Replace  Free and adjust  Adjust (see para K)
Winding rough or hard	Damaged tooth on winding gear (15, Figure 14)  Damaged tooth on winding pinion assembly (4, Figure 16)  Worn cam brake or brake pinion cam on control plate (Figure 13)  Dirty shutter	Replace  Replace  Replace worn component (See para L)  Clean (see para D)
Shutter hard to trip	Burr on trip lever assembly (Figure 13)  Too much end play on brake pinion cam (Figure 13)	Remove burr or replace  Use washers (12a, Figure 22) on shaft of brake pinion cam to limit end play to 0.001 to 0.004  (continued)

TROUBLE	CAUSE	REMEDY
Shutter will not cock	Brake pinion cam mounting hole in front housing oversize due to wear	Remove front housing swedge and ream hole to 0.078 +0.001 -0.000
	NOTE: Support housing during above operations.	
	Levers (8 & 9, Figure 12) binding.	Straighten or replace
	Broken drive spring (14, Figure 14)	Replace (use same color - see parts list)
	Damaged drive gear assembly (5, Figure 13) or winding gear assembly (15, Figure 14)	Replace
	Worn cam brake on control plate (Figure 13)	Replace (see para L)

## D. CLEANING

MATERIAL	USED ON	PURPOSE
Low pressure air, or camel hair brush	All components	Removal of loose lint and dust
Cleaning solvent	Unpainted metal parts	Removal of oil and dirt
Mild soap and water solution	Painted metal parts and plastics	Removal of oil and dirt
Lens cleaner and lens tissue	All optical elements	Removal of smudges, stain and dirt
<p><b>CAUTION</b></p> <p>For a specific application use no material other than that recommended.</p>		

## E. DISASSEMBLY - SHUTTER

Before undertaking disassembly of the 1000 Shutter, it is important that the trouble be carefully diagnosed. Use of the Trouble and Remedy Table (para C) will be a valuable aid in preliminary evaluation of the shutter. Do not plan to disassemble any further than is necessary to restore the shutter to good mechanical operating condition.

As a matter of good preventative maintenance it is recommended that components be examined for signs of wear as they are removed from the shutter. Any component adjudged to be of doubtful quality because of wear or distortion should be replaced even though it is presently causing no trouble.

To provide concise instructions and reference material for disassembly of the 1000 Shutter, obvious disassembly is not listed. The following points list only those procedures and instructions that must be observed at all times.

1. Heat should be applied to the head of a metal screw if it will not release under normal pressure.

A pencil type soldering iron is recommended as a heat source.

2. Always trip the shutter before starting disassembly.
3. Remove winding knob assembly (1, Figure 18) by turning counterclockwise.
4. Use special tools:
  - a. Tubular wrench (Figure 1) to remove front lens element.
  - b. Lens adapter (Figure 4) to retain front housing during disassembly and while testing shutter.
  - c. Friction wrench (Figure 2) to remove rear lens element.

**CAUTION**

Apply gradual pressure to friction wrench to avoid damaging lens element.

d. Spanner wrench (Figure 3) to remove retaining nut (5, Figure 11).

5. When disengaging stop pawl (9, Figure 16), apply intermittent finger pressure to stop cam (10) to allow a gradual unwinding and avoiding backlash.

6. When removing winding gear assembly (15, Figure 14), keep drive springs (14) attached to winding gear assembly. Pry the springs off the posts on the drive gear.

7. All components of the control plate (6, Figure 13) secured by screws or retaining rings can be removed without removal of the control plate from the shutter. Complete breakdown of the control plate is shown in Figure 5.

8. When removing screw (7, Figure 13) between sync. and second timer gear trains, it may be necessary to remove weight assembly in second timer train to avoid bending post on control plate.

9. Do not remove trip slide (9, Figure 10), crank follower (10) or trip link assembly (11) from shutter unless there is specific damage and one of these components requires replacement.

10. When removing front housing (Figure 8) ball (16) will be loose and under tension from spring (17).

11. If M or X sync. contact assemblies require replacement, refer to para L.

## NOTES

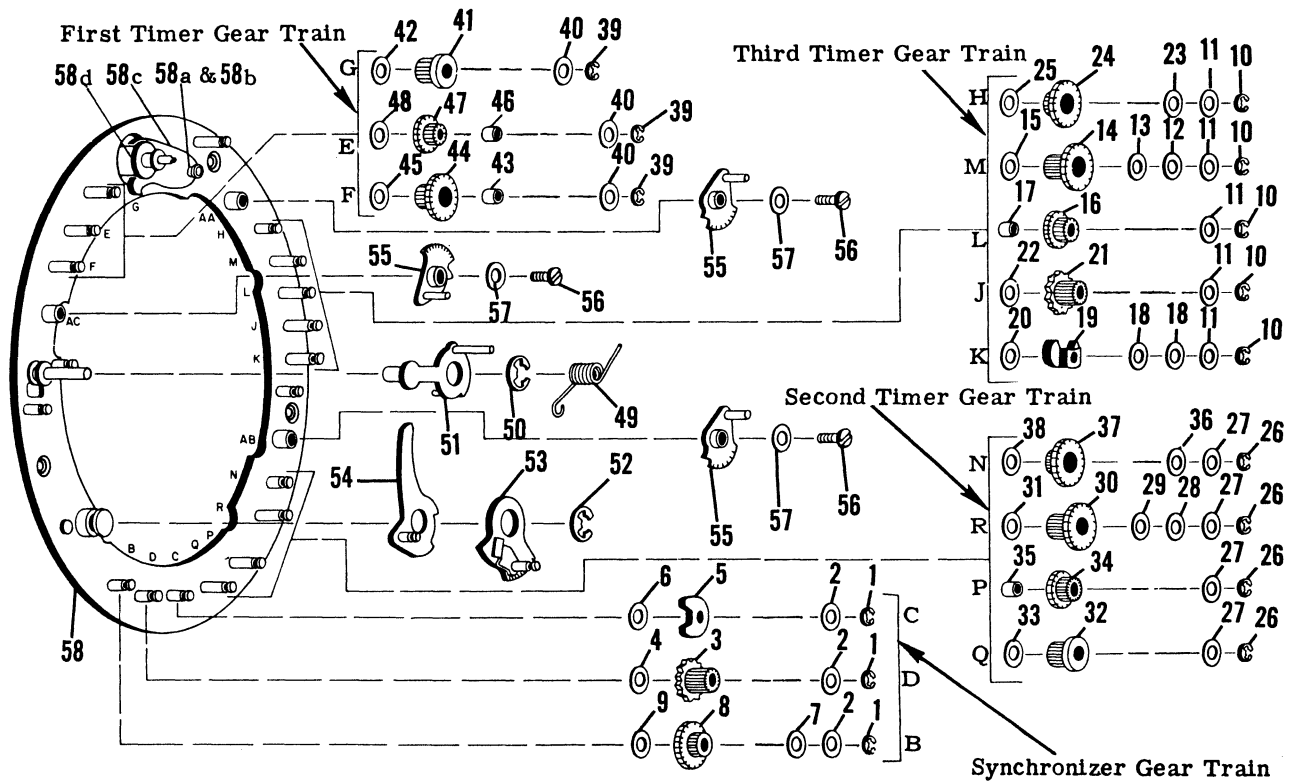

Figure 5. CONTROL PLATE COMPLETE

INDEX NO.	COMPONENT	INDEX NO.	COMPONENT
1	Ring - Retaining	32	Weight Assembly
2	Washer - Flat	33	Washer - Flat
3	Starwheel Assembly	34	Gear Assembly - Timing
4	Washer - Flat	35	Spacer
5	Pallet - Starwheel	36	Washer - Flat
6	Washer - Flat	37	Gear Assembly - Timing
7	Washer - Flat	38	Washer - Flat
8	Gear Assembly - Timing	39	Ring - Retaining
9	Washer - Flat	40	Washer - Flat
10	Ring - Retaining	41	Weight Assembly
11	Washer - Flat	42	Washer - Flat
12	Washer - Flat	43	Spacer
13	Washer - Flat	44	Gear Assembly - Timing
14	Gear Assembly - Timing	45	Washer - Flat
15	Washer - Flat	46	Spacer
16	Gear Assembly - Timing	47	Gear Assembly - Timing
17	Spacer	48	Washer - Flat
18	Washer - Flat	49	Spring - Trip
19	Pallet - Starwheel	50	Lever Assembly - Trip
20	Washer - Flat	51	Ring - Retaining
21	Starwheel Assembly	52	Ring - Retaining
22	Washer - Flat	53	Lever Assembly - Synchronizer
23	Washer - Flat	54	Latch Assembly - Trip
24	Gear Assembly - Timing	55	Dog Assembly - Timing
25	Washer - Flat	56	Screw - Machine
26	Ring - Retaining	57	Retainer - Timing Dog
27	Washer - Flat	58	Plate Assembly - Control
28	Washer - Flat	58a	Stud - Brake
29	Washer - Flat	58b	Spool - Brake
30	Gear Assembly - Timing	58c	Brake - Cam
31	Washer - Flat	58d	Cam - Brake Pinion

**F. CONTROL PLATE COMPLETE**

The exploded view of the control plate (Figure 5) and the key given with the figure shows disassembly order for completely stripping the control plate. Use the figure and key to identify components and maintain relative component positions. All procedures are obvious except for the following special instructions.

1. Index numbers 2, 11, 27, and 40 - flat washer, can be procured in thicknesses of 0.002", 0.005" and 0.008" and are used, as required, to limit end play of components assembled to a specific post to 0.003 - 0.005". Do not use a 0.002" thick washer directly under a retaining ring.

2. When assembling timing dog assembly (55) and retainer (57) to posts AC, AB and AA, do not completely tighten screws (56). Reverse control plate and apply one drop of adhesive (39491P4) to each screw hole before tightening screws.

3. As each gear train is assembled apply one drop of oil (39484P9) to each post using a 0.015" diameter wire as a dispenser. Run oil in by operating the gear train. Wipe off any excess oil.

4. When completely assembled, all gear trains must run smoothly and show no evidence of binding. If sticky action is noted when testing the trains, isolate the part causing the trouble and replace it.

5. The control plate assembly (58) includes the brake stud (58a), brake spool (58b), cam brake (58c) and brake pinion cam (58d). Refer to para L for special repairs involving these parts.

6. First timer train on current control plate is assembled as shown with spacers on top of timing gears (44 and 47). Earlier models had the spacers mounted underneath the timing gears. If an earlier model is being repaired, update the first timer train by substituting the new timing gear (44, Figure 26) on post F. Mount both spacers (43 and 46) on top of timing gears (44 and 47) as shown in Figure 5.

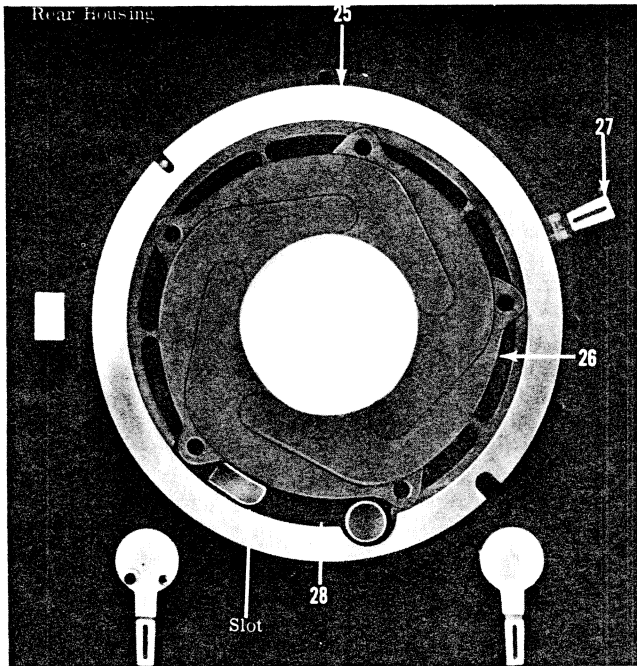

Figure 6.

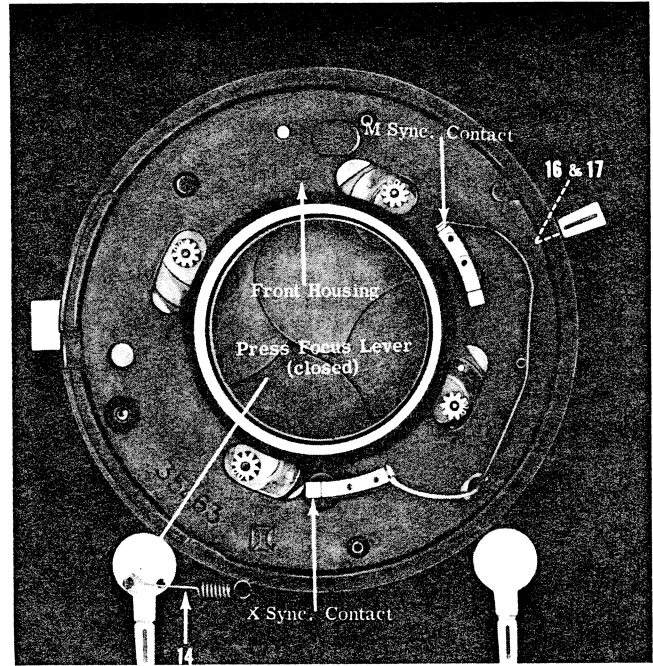

Figure 8.

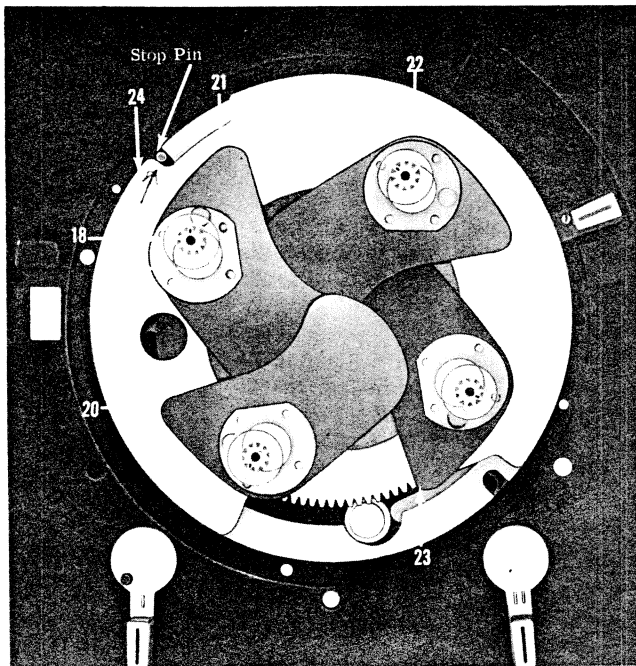

Figure 7.

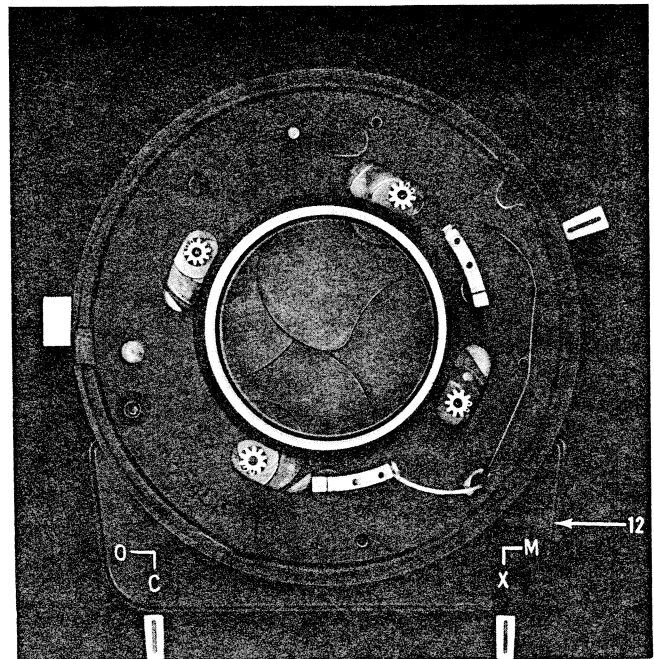

Figure 9.

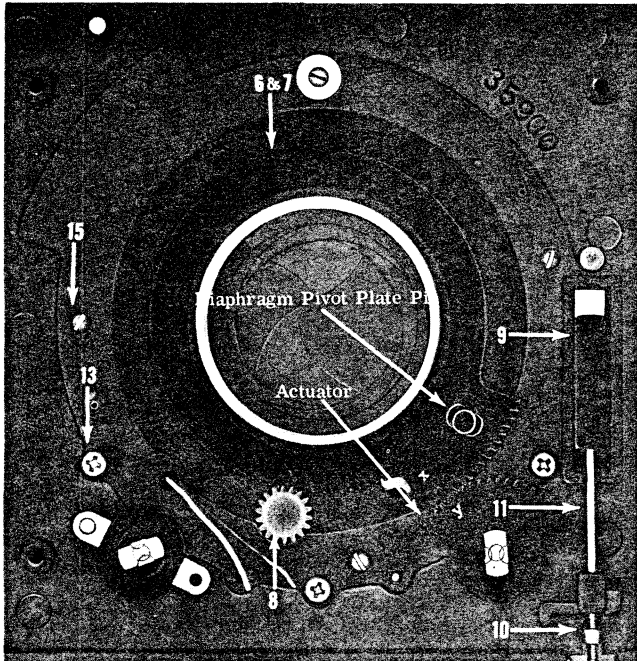

Figure 10.

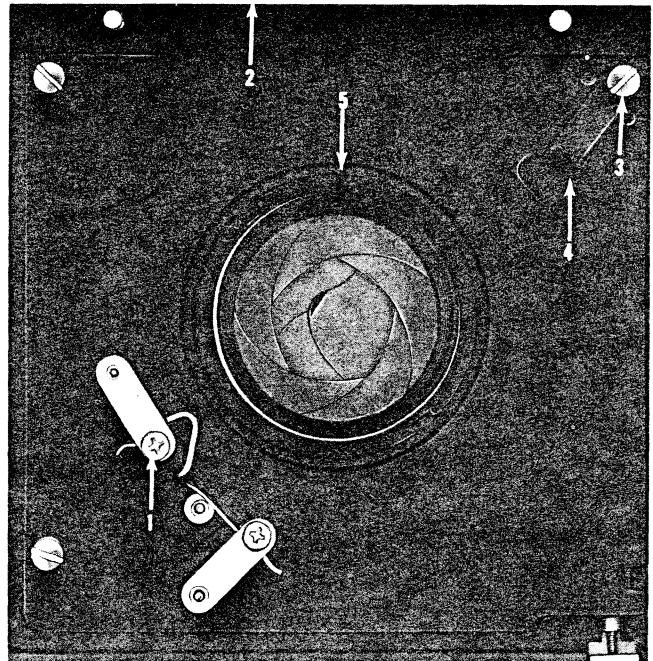

Figure 11.

**G. REASSEMBLY - SHUTTER**

The reassembly of the shutter is covered in three stages. Illustrations show all components of the shutter in their relative positions. Do not proceed to the next stage until you are sure that the stage just completed is in strict accordance with the illustrations and instructions given.

**1. Stage One:**

- a. Apply a thin coat of lubricant (39484P8) to inside diameter of diaphragm pivot plate (28, Figure 6). Locate diaphragm pivot plate in rear housing with five posts on plate facing upward and pivot on rear side located in slot in rear housing. Rotate pivot plate clockwise until pivot is against left side of slot.
- b. Locate diaphragm plate assembly (27) in rear housing with lever portion located all the way to the right (open position) in recess.
- c. Assemble five diaphragm leaf assemblies (26) over five posts on diaphragm pivot plate, interleaving diaphragm leaves as shown.
- d. Locate diaphragm pivot plate spacer (25) as shown.
- e. Assemble shutter leaf plate assembly (24, Figure 7) with four posts facing upward and stop pin on rear housing located against left side of upper opening in plate assembly.
- f. Assemble shutter leaf assemblies to four posts on shutter leaf plate assembly as follows:

- 1. To lower right post, shutter leaf

assembly (23) with bend facing downward.

- 2. To upper right post, plain shutter leaf assembly (22).
- 3. To upper left post, shutter leaf assembly (21) with flat on side.
- 4. To lower left post, shutter leaf assembly (20) with bend facing upward.

**NOTE**

Shutter leaf assemblies must lay flat against each other.

- g. Apply a light coat of lubricant (39484P9) to four shutter leaf eccentrics (19). Remove excess lubricant so that only a light film remains. Assemble one eccentric to each of the four posts on shutter leaf plate assembly and washer(s) (18), used as required, over each eccentric. (In repair, it is suggested that three be used on each post.)
- h. Apply thin coat of lubricant (39484P8) to steel ball (16, Figure 8). Insert detent spring (17) and steel ball into lever portion of diaphragm plate assembly. Depress ball and spring while positioning front housing to rear housing. Insert contact leads thru holes in front and rear housings. Apply adhesive (39490P2) to threads of four screws (15, Figure 10) and secure front housing. Check eccentrics for free movement by rotating each eccentric thru a 15° arc. If eccentric binds or moves with difficulty, remove one of the washers by reaching thru the slot in the housing with a tweezers. Recheck movement and if necessary remove the second washer.

j. On Model 2B assemble contact assembly (7, Figure 25) and secure with washer (11) and screw (8). Apply adhesive (39491P5) to threads of screw before inserting. Upper and lower screws are not assembled at this time.

k. Assemble press focus spring (14, Figure 8) to press focus lever. Press focus lever is shown in the closed position. Maintain closed position throughout reassembly.

m. Position front cover (12, Figure 9) and secure with three screws (13, Figure 10).

n. On Model 2A assemble trip link assembly (11), crank follower (10) and trip slide (9).

#### NOTE

Final adjustment of the trip link assembly is made after shutter has been completely assembled.

p. Apply a thin coat of lubricant (39484P8) all over diaphragm gear (8) and insert gear into brass eyelet. Turn gear clockwise until it stops. Maintain position.

q. Place press focus washer (7) over hub on rear housing.

r. With diaphragm gear turned fully clockwise, position press focus gear (6) over hub with slot in gear over diaphragm pivot plate pin. Mesh press focus gear teeth as follows:

1. Shutters having 135mm lens, timing mark (x) on outer sector should locate opposite timing mark (y) on actuator.

2. Shutters having 270mm lens, timing mark (x) on the outer sector should locate one half tooth counterclockwise from timing mark (y) on actuator.

s. On Model 2B, attach two wire leads to two posts on contact assembly. Place one washer (10 & 9, Figure 25) over each post and secure with two screws (8). Apply adhesive (39491P5) to threads of screws before inserting.

t. On Model 2A, position contact plate assembly (2, Figure 11) on rear housing, bringing wire leads thru hole in plate assembly. On Model 2B, position cover assembly (1, Figure 25) on rear housing.

u. Assemble retaining nut (5, Figure 11). Use Spanner wrench (Figure 3) to tighten.

v. On Model 2A, locate rangefinder cam retainer (4, Figure 11) as shown. Insert three screws (3) and tighten. On Model 2B, insert three screws (2, Figure 25) and tighten.

w. On Model 2A, position two wire leads under two contacts and secure with two screws (1, Figure 11).



*199  
dogg  
over*

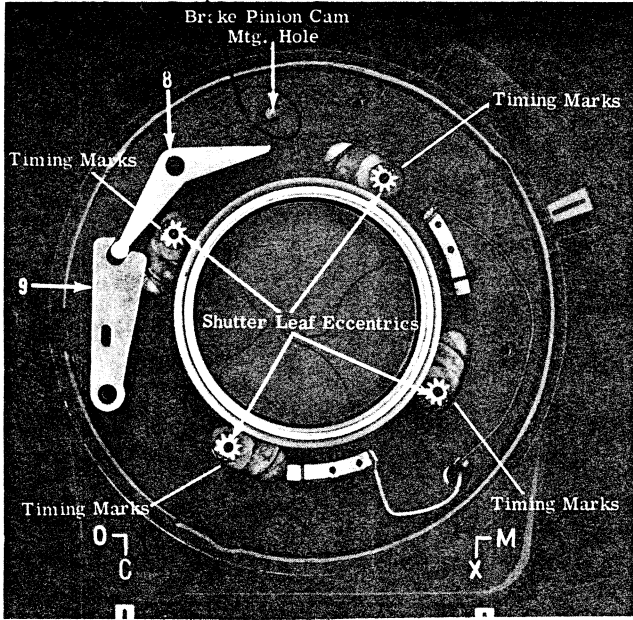

Figure 12.

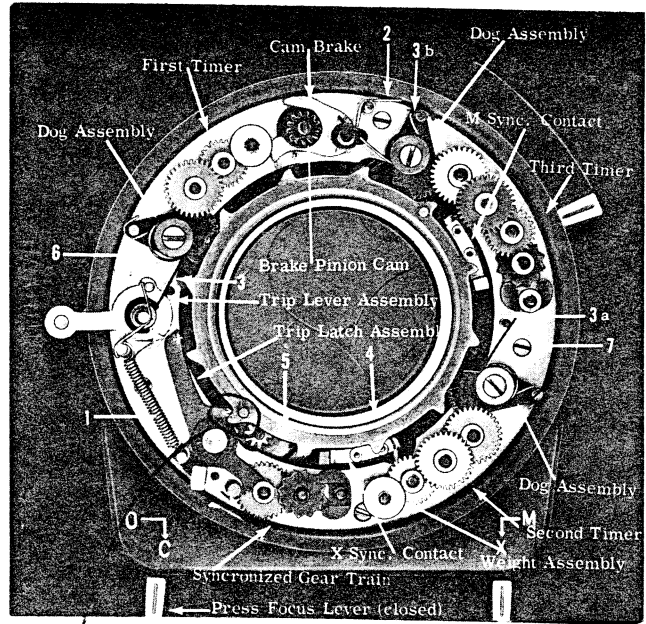

Figure 13.

*to pin against latch*

2. Stage Two:

a. Place cable release lever (9, Figure 12) and trip lever (8) over machined bosses on front housing.

b. Position wire leads as shown.

c. Before assembling control plate complete (6, Figure 13) into front housing, apply a thin coat of lubricant (39484P8) to all surfaces of brake pinion cam. Position control plate so that brake pinion cam locates in mounting hole in front housing (Figure 12), and post on trip lever assembly (Figure 13) locates in slot in cable release lever (9, Figure 12). Apply sealant (39491P4) to threads of four screws (7, Figure 13) and secure control plate.

d. Position trip latch assembly so that surface (x) is against surface (y) on trip lever assembly. Apply a thin coat of lubricant (39484P8) to contact area at tip of trip latch.

e. Locate timing marks on four shutter leaf eccentrics (Figure 12) so that centerline between timing marks of each eccentric is visually aligned to center of shutter. Timing marks on each eccentric should point directly toward outside of housing. Apply a thin coat of lubricant (39484P2) to

inside diameter and bottom surfaces of drive gear assembly (5, Figure 13). Position three dog assemblies away from center opening, and assemble drive gear so that front face of a tooth containing a spring post is against surface (z) on trip lever assembly. Do not allow any other lubricant to contact drive gear. Assemble drive gear bearing (4) with step facing up.

**CAUTION**

Do not turn drive gear counterclockwise as damage to M and X contact springs on front housing will result.

Holding drive gear in clockwise position to keep surfaces (x) and (y) in contact, move press focus lever from "C" to "0" positions several times and observe operation of shutter leaves. Shutter leaves should operate in unison from fully opened, without starting to close, to fully closed positions. If shutter leaves do not function in this manner, shutter leaf eccentrics have either moved out of position or were incorrectly positioned. If necessary, repeat this step.

f. Assemble three timer springs (3 - copper, 3a - bright and 3b - black), cam brake spring (2) and latch spring (1).

*Handwritten notes:*  
 - Drive  
 - Pinion  
 - Brake  
 - Cam  
 - Drive  
 - Gear  
 - 11  
 - 12  
 - 13  
 - 14  
 - 15  
 - 16  
 - 17  
 - 18  
 - 19  
 - 20  
 - 21  
 - 22  
 - 23  
 - 24  
 - 25  
 - 26  
 - 27  
 - 28  
 - 29  
 - 30  
 - 31  
 - 32  
 - 33  
 - 34  
 - 35  
 - 36  
 - 37  
 - 38  
 - 39  
 - 40  
 - 41  
 - 42  
 - 43  
 - 44  
 - 45  
 - 46  
 - 47  
 - 48  
 - 49  
 - 50  
 - 51  
 - 52  
 - 53  
 - 54  
 - 55  
 - 56  
 - 57  
 - 58  
 - 59  
 - 60  
 - 61  
 - 62  
 - 63  
 - 64  
 - 65  
 - 66  
 - 67  
 - 68  
 - 69  
 - 70  
 - 71  
 - 72  
 - 73  
 - 74  
 - 75  
 - 76  
 - 77  
 - 78  
 - 79  
 - 80  
 - 81  
 - 82  
 - 83  
 - 84  
 - 85  
 - 86  
 - 87  
 - 88  
 - 89  
 - 90  
 - 91  
 - 92  
 - 93  
 - 94  
 - 95  
 - 96  
 - 97  
 - 98  
 - 99  
 - 100

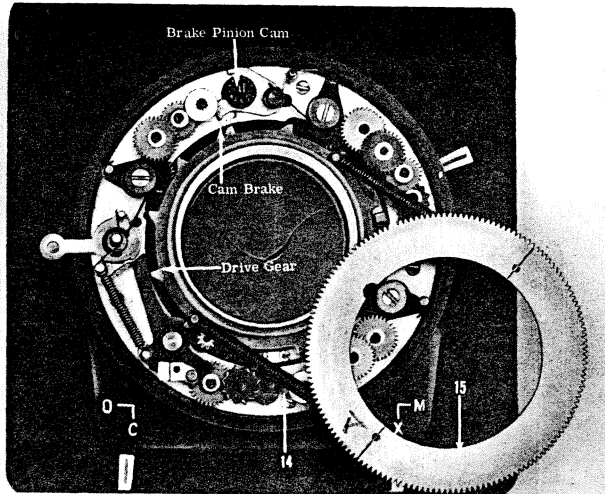

Figure 14.

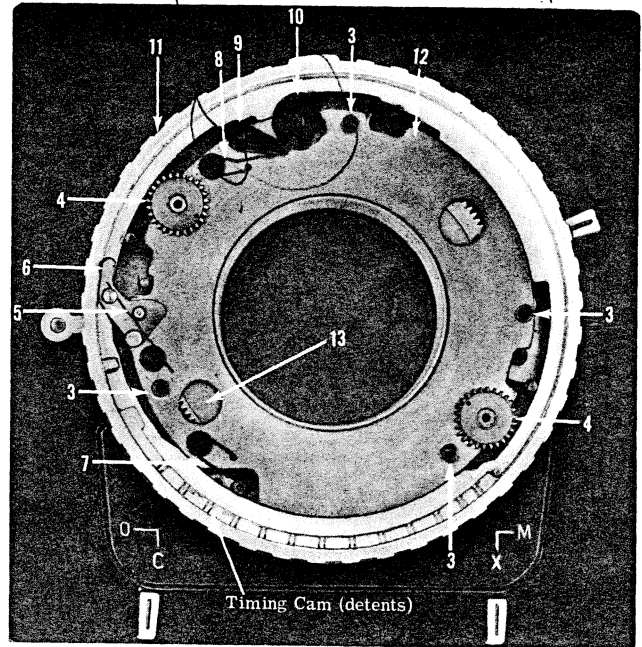

Figure 16.

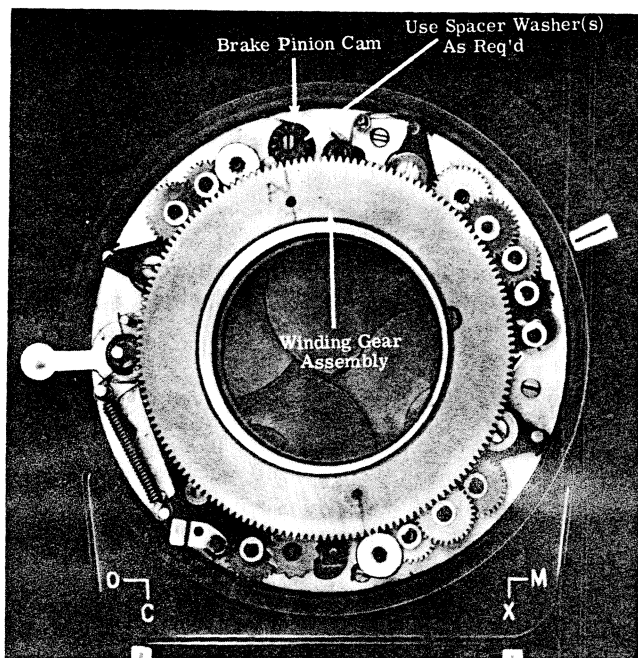

Figure 15.

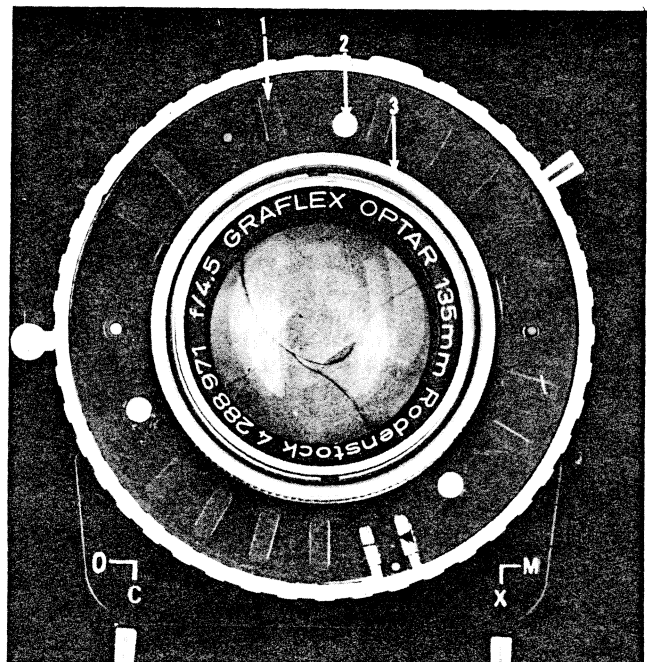

Figure 17.

3. Stage Three:

a. To facilitate alignment of winding gear (15, Figure 14), scribe a line through centerline of two posts on winding gear as shown. To each post attach a drive spring (14), attaching the opposite end of each spring to a post on drive gear. Apply a thin

coat of lubricant (39484P8) on the two drive springs and to inside diameter and top surfaces of winding gear.

b. Turn brake pinion cam until cam brake is moved into its farthest position (near the wall of

the housing). Align the brake pinion cam so that milled slot is visually aligned with center of shutter.

c. Start clockwise movement of winding gear, making sure drive springs lay in a clockwise position along the lens opening. Do not allow winding gear and brake pinion cam to engage.

d. Continue clockwise movement of winding gear until the scribed line is opposite the slot in the brake pinion cam. Back off winding gear one tooth (Figure 15), and engage winding gear and brake pinion cam in this position. (Winding gear will tend to turn in a counterclockwise direction when released. This will not influence timing as both winding gear and brake pinion cam are meshed.

e. Place spacer washer(s), if needed, on shaft of brake pinion cam to limit end play of cam to 0.001 - 0.004. (See parts list Figure 22 Index 12a).

f. Place washer (13, Figure 16) and bearing plate (12) over lens opening.

#### NOTE

For the following stages of assembly the use of the lens adapter tool (Figure 4) will contain the bearing plate and other components securely within the shutter during balance of shutter assembly. Shutter tests can be made without installing front lens.

Apply a thin coat of lubricant (39484P8) to bearing surfaces of winding knob gear (3, Figure 17) and position over lens opening. Thread lens adapter tool into lens opening.

g. Apply a thin coat of lubricant (39484P8) to inside bearing surfaces and detents on timing cam (11, Figure 16). Orient timing cam on front housing by locating the red dot on cam opposite the "0" position on the timing scale. Using an offset counterclockwise movement, compress the second timing dog post within the inside diameter of the cam. Continuing with the offset counterclockwise movement, compress the third timing dog post, and finally, the first timing dog post. With all posts contained within the inside diameter of the cam, the cam will snap into position.

h. Apply a thin coat of lubricant (39484P8) to periphery of cam stop (10), and assemble cam stop and stop pawl (9) as shown. Assemble pawl stop spring (8), synchronizer lever spring (7), bulb lever assembly (6) and bulb lever spring (5).

j. Apply a thin coat of lubricant (39484P8) to pinion, journal and gear teeth on two winding pinions (4). Insert winding pinions through their respective holes in bearing plate, facing timing marks on pinion toward inside and visually aligned with center of shutter.

k. Place four cover spacers (3) over four holes in bearing plate as shown. Locate bearing

plate cover (1, Figure 17) over bearing plate. Apply small amount of adhesive (39490P2) to threads of three screws (2) and secure cover. Front and rear lens elements are not assembled into shutter at this time. Elements are assembled after all shutter tests have been made.

#### NOTE

If lens adapter tool is not used, the front lens element must be assembled in shutter so that components within the front housing remain secure throughout the shutter tests.

m. Assemble winding knob assembly (1, Figure 18).

n. Set timing cam at "B" position, cock shutter and trip. Set cam at "0" position, cock shutter and trip.

#### CAUTION

Never rewind shutter in "0" position. Close leaves by turning timing cam to another speed position before cocking shutter.

Repeat this procedure approximately fifteen times to check mechanical operation of the shutter. If any abnormal operating condition is noted refer to Malfunction Chart (para H) before proceeding further.

p. Check shutter speeds as per para. J.

q. Make necessary adjustments as per para. K.

r. Remove winding knob assembly (1) and lens adapter tool. Thread front lens element into front housing using tubular wrench (Figure 1) to tighten.

s. Using a 0.015" wire as a dispenser, apply a drop of free-running adhesive (39490P2) to three points on threads of rear lens element. Thread rear lens, finger tight, into rear housing.

t. Assemble winding knob.

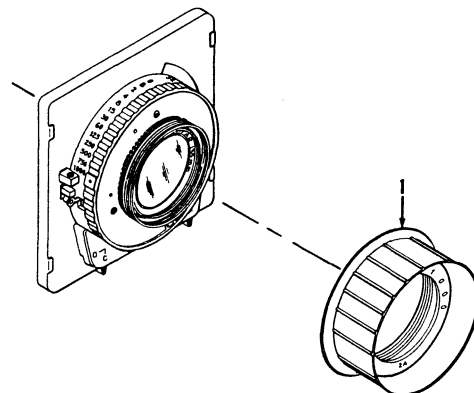

Figure 18.

H. MALFUNCTIONS (MECHANICAL)

Upon completion of reassembly the shutter should operate mechanically. If any detail has been over-

looked in the step-by-step reassembly procedure, particularly in the timing, mechanical movement in the shutter will be impaired. The Malfunction Chart is designed to help locate the source of mechanical failure and make the necessary corrections.

MALFUNCTION	CAUSE	CORRECTIVE ACTION
Shutter leaves remain open after trip cycle	Drive gear assembled while press focus lever was in "0" position	Disassemble to remove drive gear assembly. Set press focus lever in "C" position. Retime leaves (para G. 2. e.) and complete reassembly.
Shutter will not trip or cock	Incorrect timing between winding gear and brake pinion cam	Disassemble to remove winding gear. Retime gears (para G. 3. a.) and complete reassembly.
Shutter leaves partially close with press focus lever in "0" position	Incorrect timing of diaphragm gear or drive gear	Disassemble to remove diaphragm gear. Retime diaphragm gear (para G. 1. p.) and complete reassembly. If trouble persists check for assembly of drive gear with press focus lever in "0" position.
One shutter leaf lagging or leading others	Incorrect timing of drive gear	Disassemble to remove drive gear assembly. Set press lever in "C" position. Retime leaves (para G. 2. e.) and complete reassembly.

J. TESTS

Use test equipment as specified in para. A to check shutter speeds, "M" synchronization time delay and "X" synchronization.

SHUTTER SPEEDS	
SHUTTER SETTING	ASA TOLERANCE
1000	000.7 - 001.3 ms.
500	001.4 - 002.9 ms.
250	002.8 - 005.2 ms.
1/125	005.6 - 010.4 ms.
1/60	013.3 - 021.0 ms.
1/30	026.0 - 040.0 ms.
1/15	053.0 - 086.0 ms.
1/8	100.0 - 165.0 ms.
1/4	200.0 - 300.0 ms.
1/2	375.0 - 600.0 ms.

"M" SYNCHRONIZATION TIME DELAY	
SHUTTER SETTING	DELAY TOLERANCE
750	16.0 - 24.0 ms.
500	16.0 - 24.0 ms.
250	16.0 - 24.0 ms.
1/125	14.0 - 20.0 ms.
1/60	9.0 - 16.0 ms.
1/30	00.0 - 12.0 ms.

K. TEST ADJUSTMENTS

1. If tests indicate shutter speeds are out of tolerance, adjust the appropriate timer or gear train (Figure 19) as follows:

- a. Fast - Change to heavier weight or pallet.
- b. Slow - Change to lighter weight or pallet. If speeds have not been brought within tolerance after the initial adjustment, make the following adjustment to the timing cam assembly (Figure 20).

- 1. Fast - File
- 2. Slow - Swedge

**CAUTION**

Never file or swedge cam sectors for 1/125, 1/2 or 1/30. Make corrections to the cam assembly in very small increments and test before further displacement or removal of material.

2. If "M" synchronization is fast or slow, adjust the "M" synchronization contact assembly (Figure 19) as follows:

- a. Fast - Bend contact toward ratchet of drive gear or use heavier pallet.
- b. Slow - Bend contact away from ratchet of drive gear or use lighter pallet.

4. If "X" synchronization is fast or slow, adjust the "X" synchronization contact assembly (Figure 19) as follows:

- a. Fast - Bend contact away from ratchet of drive gear.
- b. Slow - Bend contact toward ratchet of drive gear.

5. After all tests and above adjustments have been completed satisfactorily, adjust trip link assembly (Figure 10) to trip shutter at end of 0.090" to 0.095" travel of tripping mechanism (9, 10, 11). Maintain this adjustment by applying a small amount of adhesive (39491P4) to threads of trip link assembly.

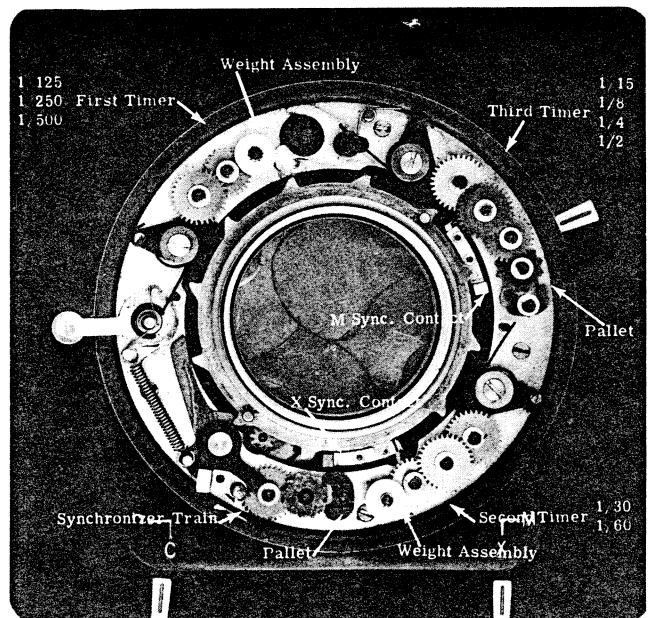

Figure 19.

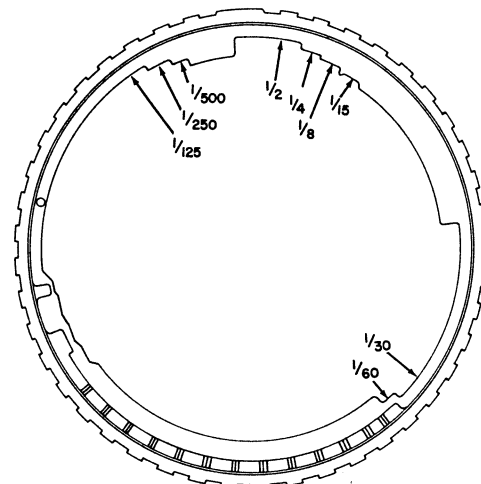

Figure 20.

## L. SPECIAL REPAIRS

## 1. Replacing "M" or "X" Contacts:

- a. Disassemble Shutter
- b. Pull contact support, contact assembly, insulator and two rivets from front housing with pliers.
- c. Clean area with solvent (Chlorothene)
- d. Replace all components (see parts list).
- e. Insert two rivets through housing and place housing on a firm support so that rivets are seated in their countersunk holes.
- f. Apply small amount of adhesive (39490P2) between rivets and assemble insulator over two rivets.
- g. Apply small amount of adhesive

(39490P2) to underside of contact support over two rivets.

h. Use a pencil type soldering iron (modify tip to accept and to form end of rivet). Push firmly on iron to form and weld over ends of rivets. Avoid overheating iron.

## 2. Replacing Cam Brake or Brake Pinion Cam

- a. Remove Control Plate Complete from front housing.
- b. Grind riveted end of brake stud and remove spool, brake and pinion brake cam.
- c. Replace damaged components (see parts list).
- d. Assemble cam, stud, brake and spool. Support control plate and rivet over end of stud. After riveting, brake must slide freely back and forth in its mounting hole without binding.

## INTRODUCTION TO PARTS LIST

The Group Assembly Parts Lists are listed in disassembly order. The list divides the components into major assemblies, their subassemblies and parts. By the use of indented columns, the relationship of the assemblies to the subassemblies and parts is obtained.

The column titled "Figure and Index No." contains the index number in disassembly order of the items illustrated. Do not use the figure or index number in correspondence--specify the catalog or part number and name. Finish should also be included where specified.

The column titled "nomenclature" (including numbered columns) lists item nomenclature on the Graflex drawing. The assembly in the column marked "3" will be a component of the first assembly which preceded it in the column marked "2" etc. The code "NP" will indicate that this part is "not procurable" and that the "next higher assembly" (NHA) should be ordered. The code "AR" is used for bulk items when an indefinite amount may or may not be used "as required. The code "LP" is used when an item may be "locally purchased."

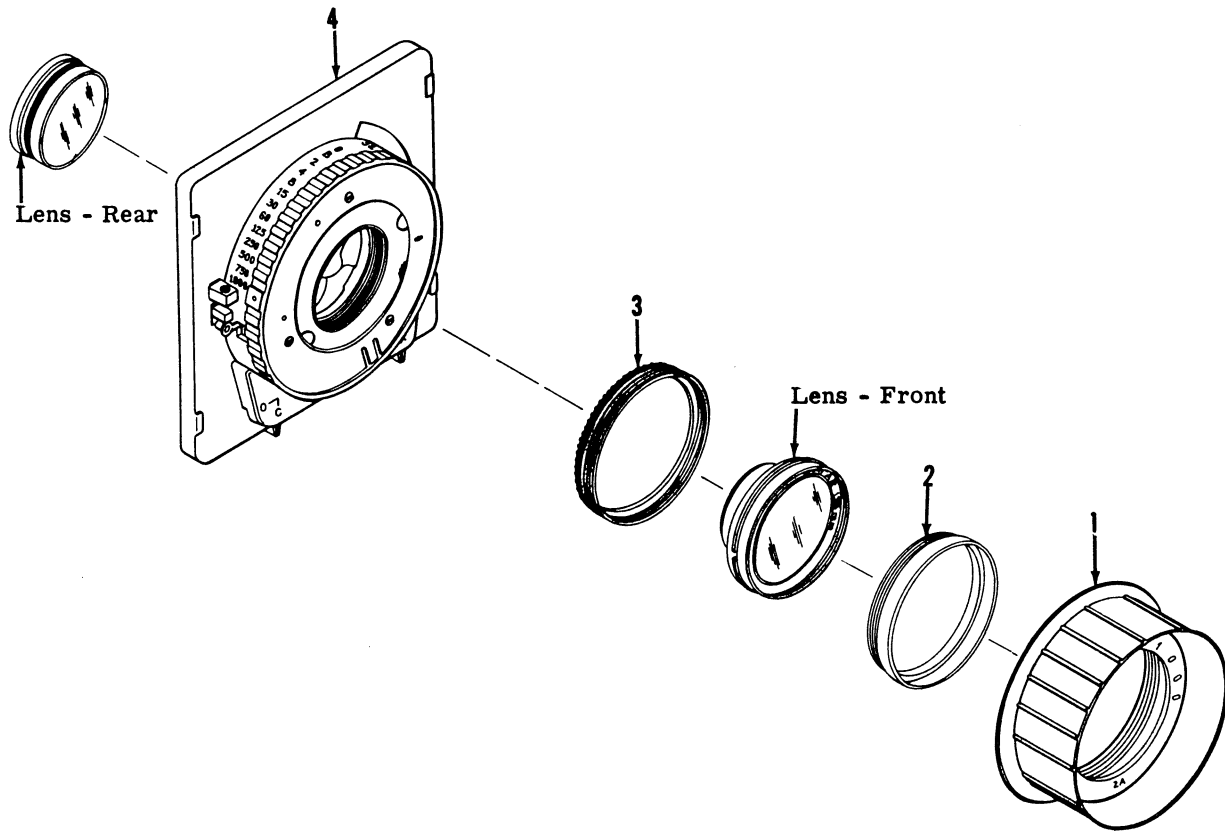

Figure 21. GRAFLEX 1000 SHUTTER

Figure and Index No.	Part Number	1	2	3	4	5	Nomenclature	Qty.
21-	35350G2 (Cat. 540)						GRAFLEX 1000 SHUTTER (Model 2A, f/4.5 135mm lens) . . .	1
	35350G4 (Cat. 542)						GRAFLEX 1000 SHUTTER (Model 2B, f/4.5 135mm lens) . . .	Discontinued
	35350G5 (Cat. 581)						GRAFLEX 1000 SHUTTER (Model 2A, f/6.5 270mm lens) . . .	1
	35350G6 (Cat. 583)						GRAFLEX 1000 SHUTTER (Model 2B, f/6.5 270mm lens) . . .	Discontinued
-1	35489G1						Knob Assembly - Winding (Model 2A) . . . . .	1
	35489G2						Knob Assembly - Winding (Model 2B) . . . . .	1
	35474P1						Nameplate (Model 2A) . . . . .	1
	35474P2						Nameplate (Model 2B) . . . . .	1
-2	35916P1						Retainer - Filter (used on early models - replace with Index 3) . . . . .	Ref.
							Lens - Rear . . . . .	Ref.
							Lens - Front . . . . .	Ref.
-3	35471P1						Gear - Winding Knob (new style - see note below) . . . . .	1
-4	35352G2						Shutter Assembly - Third (used on 35350G2) Figure 22 . . .	1
	35352G3						Shutter Assembly - Third (used on 35350G4) Figure 22 . . .	Ref.
	35352G4						Shutter Assembly - Third (used on 35350G5) Figure 22 . . .	1
	35352G5						Shutter Assembly - Third (used on 35350G6) Figure 22 . . .	Ref.

NOTE: New style winding knob gear incorporates a filter retainer.

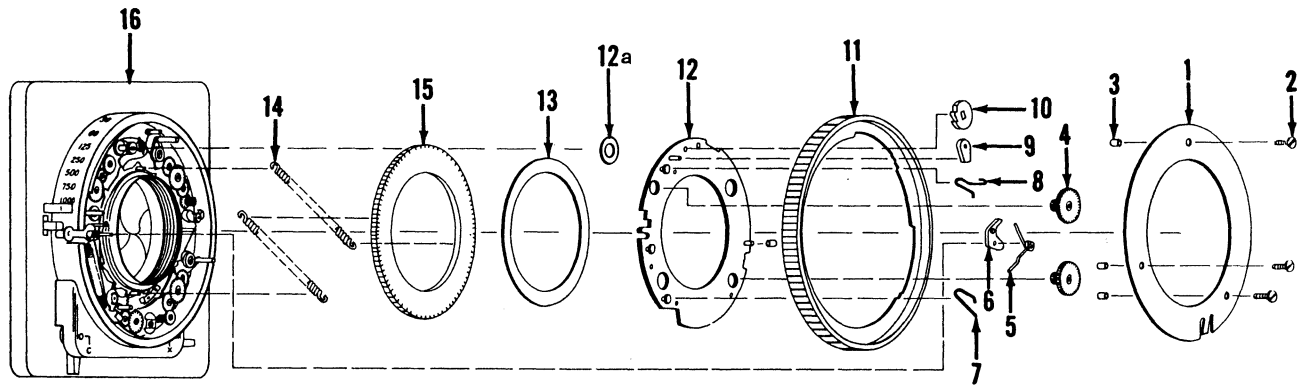

Figure 22. SHUTTER ASSEMBLY - THIRD

Figure and Index No.	Part Number	1	2	3	4	5	Nomenclature	Qty.
22-	35352G2						SHUTTER ASSEMBLY - THIRD (Model 2A, f/4.5 135mm lens)	Ref.
	35352G3						SHUTTER ASSEMBLY - THIRD (Model 2B, f/4.5 135mm lens)	Ref.
	35352G4						SHUTTER ASSEMBLY - THIRD (Model 2A, f/6.5 270mm lens)	Ref.
	35352G5						SHUTTER ASSEMBLY - THIRD (Model 2B, f/6.5 270mm lens)	Ref.
-1	35483G1						Cover Assembly - Bearing Plate	1
	Attaching Part							
-2	35044P3						Screw - Machine (special)	3
	---***---							
-3	35468						Spacer - Cover	4
-4	35366G1						Pinion Assembly - Winding	2
-5	35935						Spring - Bulb Lever	1
-6	35937G1						Lever Assembly - Bulb	1
-7	35359						Spring - Synchronizer Lever	1
-8	35354P1						Spring - Pawl	1
-9	35355						Pawl - Stop	1
-10	35356P1						Cam - Stop	1
-11	35919G3						Cam Assembly - Timing (no spacer on pin - used on shutters bearing serial number 12,000 and up)	1
	35919G2						Cam Assembly - Timing (no spacer on pin - used on shutters bearing serial number up to 11,999)	1
	35919G1						Cam Assembly - Timing (with spacer on pin - used on shutters bearing serial number up to 11,999)	1
-12	35373G1						Plate Assembly - Bearing	1
-12a	38473-27						Washer - Flat, 0.140 x 0.084 x 0.002	AR
-13	35473-15						Washer - Flat, 1.781 x 1.390 x 0.005	1
-14	35979P1						Spring - Drive (bright finish - used on shutters bearing serial number 12,000 and up)	2
	35372						Spring - Drive (black finish - used on shutters bearing serial number up to 11,999)	2
-15	35369G1						Gear Assembly - Winding	1
-16	35408G2						Shutter Assembly - Second (used on 35352G2) Figure 23	Ref.
	35408G3						Shutter Assembly - Second (used on 35352G3) Figure 23	Ref.
	35408G4						Shutter Assembly - Second (used on 35352G4) Figure 23	Ref.
	35408G5						Shutter Assembly - Second (used on 35352G5) Figure 23	Ref.



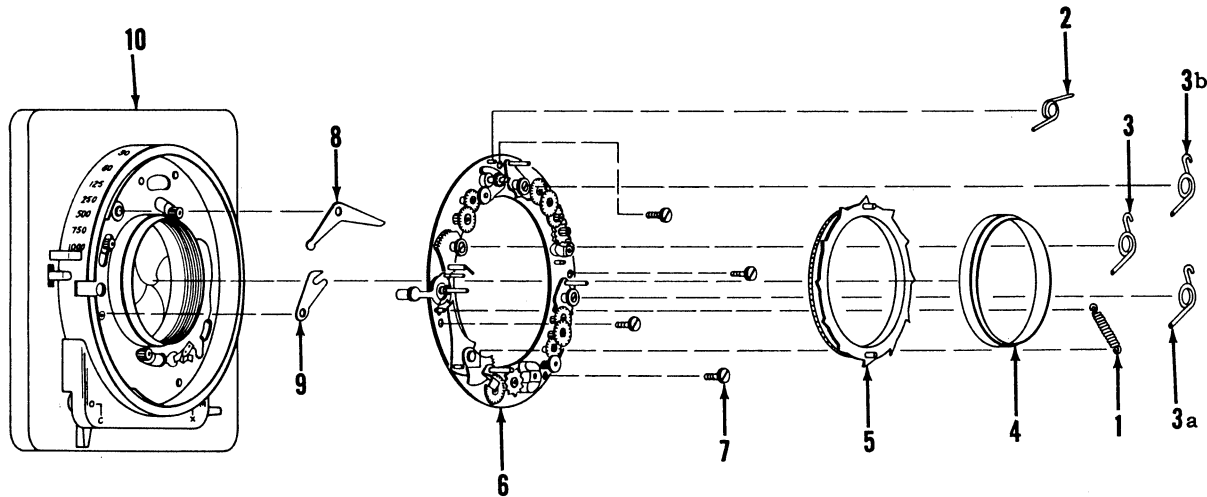

Figure 23. SHUTTER ASSEMBLY - SECOND

Figure and Index No.	Part Number	1	2	3	4	5	Nomenclature	Qty.
23-	35408G2						SHUTTER ASSEMBLY - SECOND (Model 2A, f/4.5 135mm lens)	Ref.
	35408G3						SHUTTER ASSEMBLY - SECOND (Model 2B, f/4.5 135mm lens)	Ref.
	35408G4						SHUTTER ASSEMBLY - SECOND (Model 2A, f/6.5 270mm lens)	Ref.
	35408G5						SHUTTER ASSEMBLY - SECOND (Model 2B, f/6.5 270mm lens)	Ref.
-1	35388						. Spring - Latch . . . . .	1
-2	35389						. Spring - Cam Brake . . . . .	1
-3	35387P3						. Spring - First Timer (copper finish) replaces 35387P1 . . . . .	1
-3a	35387P4						. Spring - Second Timer (bright finish) replaces 35387P1 . . . . .	1
-3b	35387P5						. Spring - Third Timer (black finish) replaces 35387P1 . . . . .	1
	35387P1						. Spring - Timer (replace with indices 3, 3a and 3b) . . . . .	Ref.
-4	35484P1						. Bearing - Drive Gear . . . . .	1
-5	35414G1						. Gear Assembly - Drive . . . . .	1
-6	35378G1						. Plate Complete - Control (Figure 26) . . . . .	1
	Attaching Part							
-7	35412P1						. Screw - Machine (special) . . . . .	4
	---***---							
-8	35409P1						. Lever - Trip Interlock (0.025 in. thk.) . . . . .	1
	35409P2						. Lever - Trip Interlock (0.020 in. thk.) . . . . .	1
-9	35410P1						. Lever - Cable Release (0.025 in. thk.) . . . . .	1
	35410P2						. Lever - Cable Release (0.020 in. thk.) . . . . .	1
-10	35436G2						. Shutter Assembly - First (used on 35408G2) Figure 24 . . . . .	Ref.
	35436G3						. Shutter Assembly - First (used on 35408G3) Figure 25 . . . . .	Ref.
	35436G4						. Shutter Assembly - First (used on 35408G4) Figure 24 . . . . .	Ref.
	35436G5						. Shutter Assembly - First (used on 35408G5) Figure 25 . . . . .	Ref.

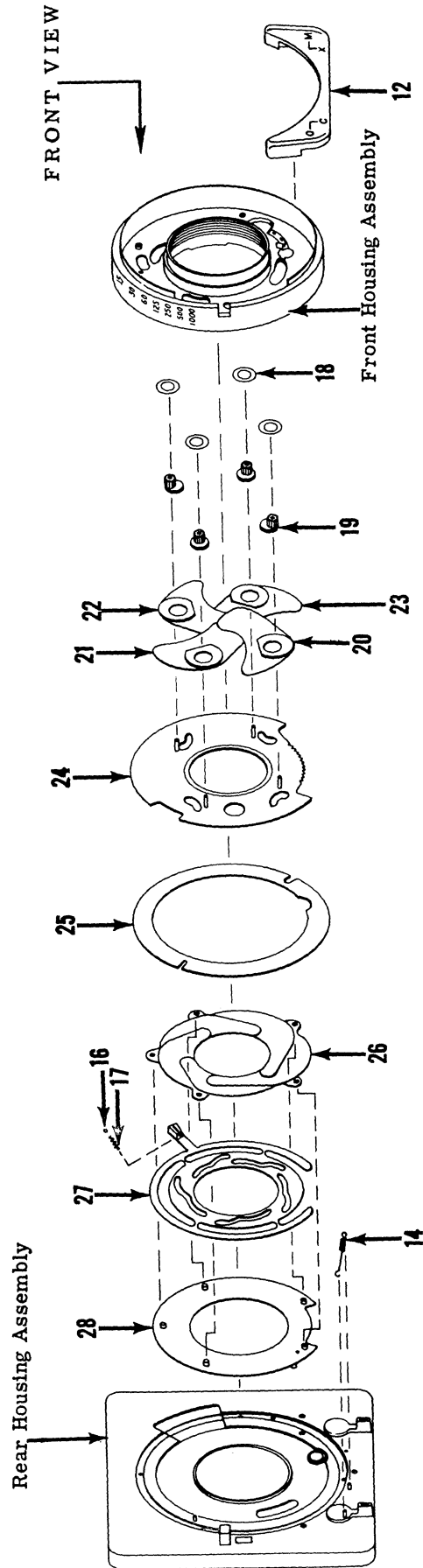
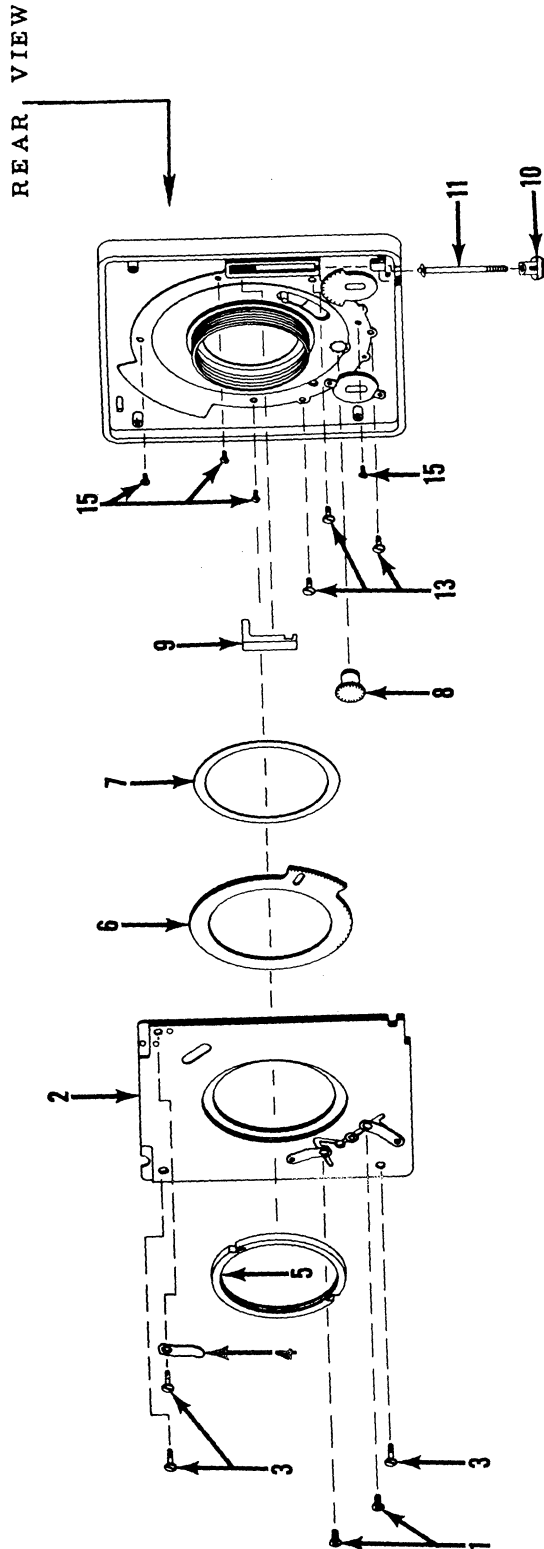
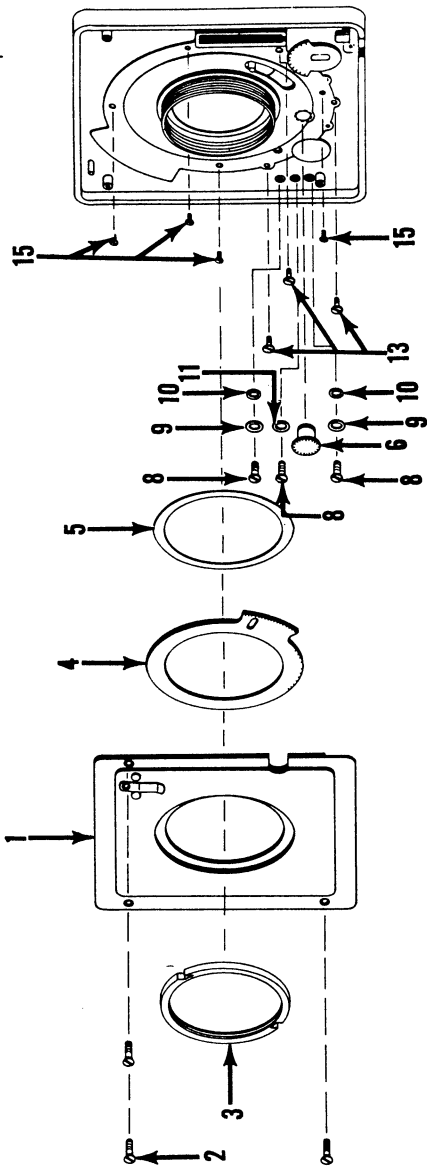

Figure 24. SHUTTER ASSEMBLY - FIRST (Model 2A)

Figure and Index No.	Part Number	1	2	3	4	5	Nomenclature	Qty.
24-	35436G2						SHUTTER ASSEMBLY - FIRST (Model 2A, f/4.5 135mm lens).	Ref.
	35436G4						SHUTTER ASSEMBLY - FIRST (Model 2A, f/6.5 270mm lens).	Ref.
-1	121-2R2A						. Screw - Thread Forming, No. 2 x 1/8 pan hd (was 30921P36A)	2
-2	35917G1						. Plate Assembly - Contact. . . . .	1
	Attaching Parts							
-3	110-2-3A						. Screw - Machine, No. 2-56 x 3/16 binding hd . . . . .	3
-4	35470						. Retainer - Cam . . . . .	1
-5	35910						. Nut - Retaining. . . . .	1
	---***---							
-6	35907P1						. Gear - Press Focus (used with 35436G2) . . . . .	1
	35907P2						. Gear - Press Focus (used with 35436G4) . . . . .	1
-7	35923						. Washer - Press Focus. . . . .	1
-8	35922P1						. Gear - Diaphragm. . . . .	1
-9	35926						. Slide - Trip. . . . .	1
-10	35928						. Follower - Crank . . . . .	1
-11	35974G1						. Link Assembly - Trip . . . . .	1
	35473-28						. Washer - Flat, 0.100 x 0.046 x 0.0075. . . . .	1
-12	35911P1						. Cover - Front . . . . .	1
	Attaching Part							
-13	33921-15A						. Screw - Self Threading, No. 2 x 1/4 pan hd. . . . .	3
	---***---							
-14	35902						. Spring - Press Focus . . . . .	1
							. Housing Assembly - Front and Rear. . . . .	Ref.
	Attaching Part							
-15	35976						. Screw - Machine (special) . . . . .	4
	---***---							
-16	300-3						. Ball - Steel (0.0625) . . . . .	1
-17	35934						. Spring - Detent . . . . .	1
-18	35473-21						. Washer - Flat, 0.275 x 0.156 x 0.002 . . . . .	AR
-19	35442P1						. Eccentric - Shutter Leaf . . . . .	4
-20	35445G2						. Leaf Assembly - Shutter (bend upward). . . . .	1
-21	35445G4						. Leaf Assembly - Shutter (flat on edge) replaces 35445G1. . . . .	1
-22	35445G1						. Leaf Assembly - Shutter (plain). . . . .	1
-23	35445G3						. Leaf Assembly - Shutter (bend downward). . . . .	1
-24	35437G1						. Plate Assembly - Shutter Leaf . . . . .	1
-25	35453P1						. Spacer - Diaphragm Pivot Plate . . . . .	1
-26	35457G1						. Leaf Assembly - Diaphragm. . . . .	5
-27	35441G1						. Plate Assembly - Diaphragm . . . . .	1
-28	35454P1						. Plate - Diaphragm Pivot . . . . .	1
	35436G9						. Housing Assembly - Front and Rear (matched set) used on 35436G2 . . . . .	NP NHA
	35436G11						. Housing Assembly - Front and Rear (matched set) used on 35436G4 . . . . .	NP NHA
							. . . Housing Assembly - Front . . . . .	Ref.
	35939P2						. . . Strip - Index (used on 35436G9) . . . . .	1
	35939P3						. . . Strip - Index (used on 35436G11). . . . .	1
	35435						. . . Rivet - Contact . . . . .	4
	35480						. . . Support - Contact. . . . .	2
	35431G1						. . . Contact Assembly (X sync) . . . . .	1
	35431G2						. . . Contact Assembly (M sync) . . . . .	1
	35434						. . . Insulator - Contact. . . . .	2
							. . . Housing Front. . . . .	Ref.
							. . . Housing Assembly - Rear . . . . .	Ref.

REAR VIEW



FRONT VIEW

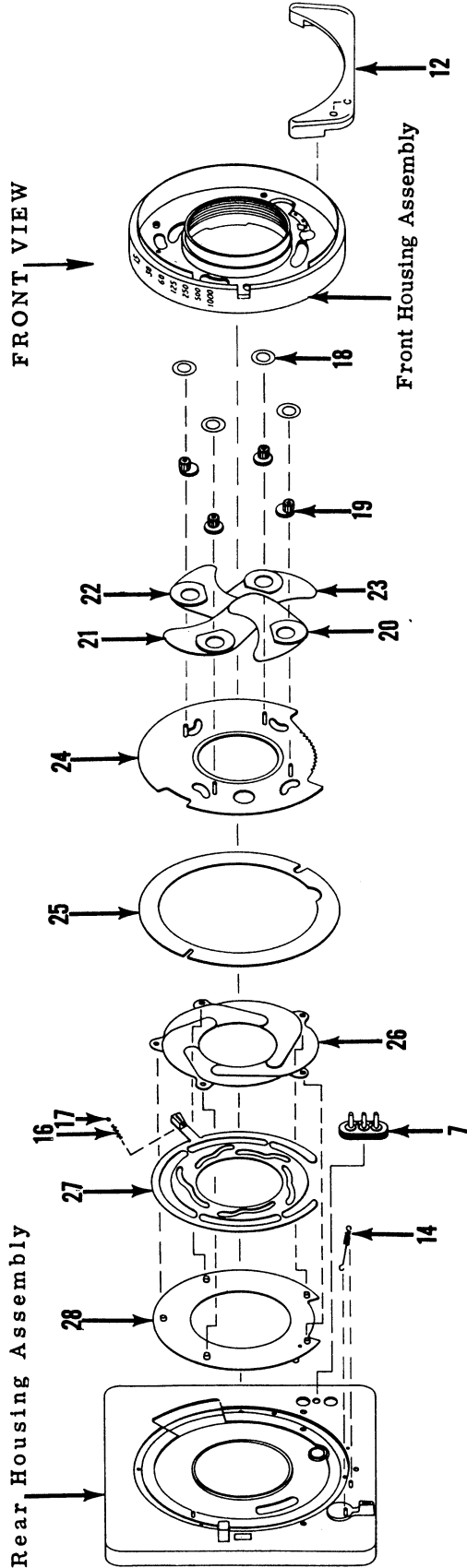

Figure 25. SHUTTER ASSEMBLY - FIRST (Model 2B)

Figure and Index No.	Part Number	1	2	3	4	5	Nomenclature	Qty.
25-	35436G3						SHUTTER ASSEMBLY - FIRST (Model 2B, f/4.5 135mm lens)	Ref.
	35436G5						SHUTTER ASSEMBLY - FIRST (Model 2B, f/6.5 270mm lens)	Ref.
-1	35975G1						. Cover Assembly - Rear Housing (135mm lens) . . . . .	1
	35975G2						. Cover Assembly - Rear Housing (270mm lens) . . . . .	1
	33561-2						. . Rivet . . . . .	1
	35470						. . Retainer - Rangefinder Cam . . . . .	1
	Attaching Parts							
-2	100-2-2A						. Screw - Machine, No. 2-56 x 1/8 flat hd. . . . .	3
-3	35910						. Nut - Retainer . . . . .	1
	---***---							
-4	35907P1						. Gear - Press Focus (used on 35436G3) . . . . .	1
	35907P2						. Gear - Press Focus (used with 35436G5) . . . . .	1
-5	35923						. Washer - Press Focus . . . . .	1
-6	35922P1						. Gear - Diaphragm . . . . .	1
-7	35970G1						. Contact Assembly . . . . .	1
	Attaching Parts							
-8	112B1-2						. Screw - Machine, No. 2-56 x 1/8 flat hd. . . . .	3
-9	35473-41						. Washer - Flat, 0.187 x 0.076 x 0.016 . . . . .	2
-10	35473-43						. Washer - Flat, 0.218 x 0.076 x 0.015 . . . . .	2
-11	35473-40R						. Washer - Flat, 0.187 x 0.076 x 0.032 . . . . .	1
	---***---							
-12	35911P2						. Cover - Front . . . . .	1
	Attaching Part							
-13	33921-15A						. Screw - Self Threading, No. 2 x 1/4 pan hd. . . . .	3
	---***---							
-14	35902						. Spring - Press Focus . . . . .	1
							. Housing Assembly - Front and Rear . . . . .	Ref.
	Attaching Part							
-15	35976						. Screw - Machine (special) . . . . .	4
	---***---							
-16	300-3						. Ball - Steel (0.0625) . . . . .	1
-17	35934						. Spring - Detent . . . . .	1
-18	35473-21						. Washer - Flat, 0.275 x 0.156 x 0.002 . . . . .	AR
-19	35442P1						. Eccentric - Shutter Leaf . . . . .	4
-20	35445G2						. Leaf Assembly - Shutter (bend upward) . . . . .	1
-21	35445G4						. Leaf Assembly - Shutter (flat on edge) replaces 35445G1 . . . . .	1
-22	35445G1						. Leaf Assembly - Shutter (plain) . . . . .	1
-23	35445G3						. Leaf Assembly - Shutter (bend downward) . . . . .	1
-24	35437G1						. Plate Assembly - Shutter Leaf . . . . .	1
-25	35453P1						. Spacer - Diaphragm Pivot Plate . . . . .	1
-26	35457G1						. Leaf Assembly - Diaphragm . . . . .	5
-27	35441G1						. Plate Assembly - Diaphragm . . . . .	1
-28	35454P1						. Plate - Diaphragm Pivot . . . . .	1
	35436G10						. Housing Assembly - Front and Rear (matched set) used on 35436G3 . . . . .	NP
								NHA
	35436G12						. Housing Assembly - Front and Rear (matched set) used on 35436G5 . . . . .	NP
								NHA
							. . Housing Assembly - Front . . . . .	Ref.
	35939P2						. . . Strip - Index (used on 35436G10) . . . . .	1
	35939P3						. . . Strip - Index (used on 35436G12) . . . . .	1
	35435						. . . Rivet - Contact . . . . .	4
	35480						. . . Support - Contact . . . . .	2
	35431G1						. . . Contact Assembly (X sync) . . . . .	1
	35431G2						. . . Contact Assembly (M sync) . . . . .	1
	35434						. . . Insulator - Contact . . . . .	2
							. . . Housing - Front . . . . .	Ref.
							. . . Housing Assembly - Rear . . . . .	Ref.

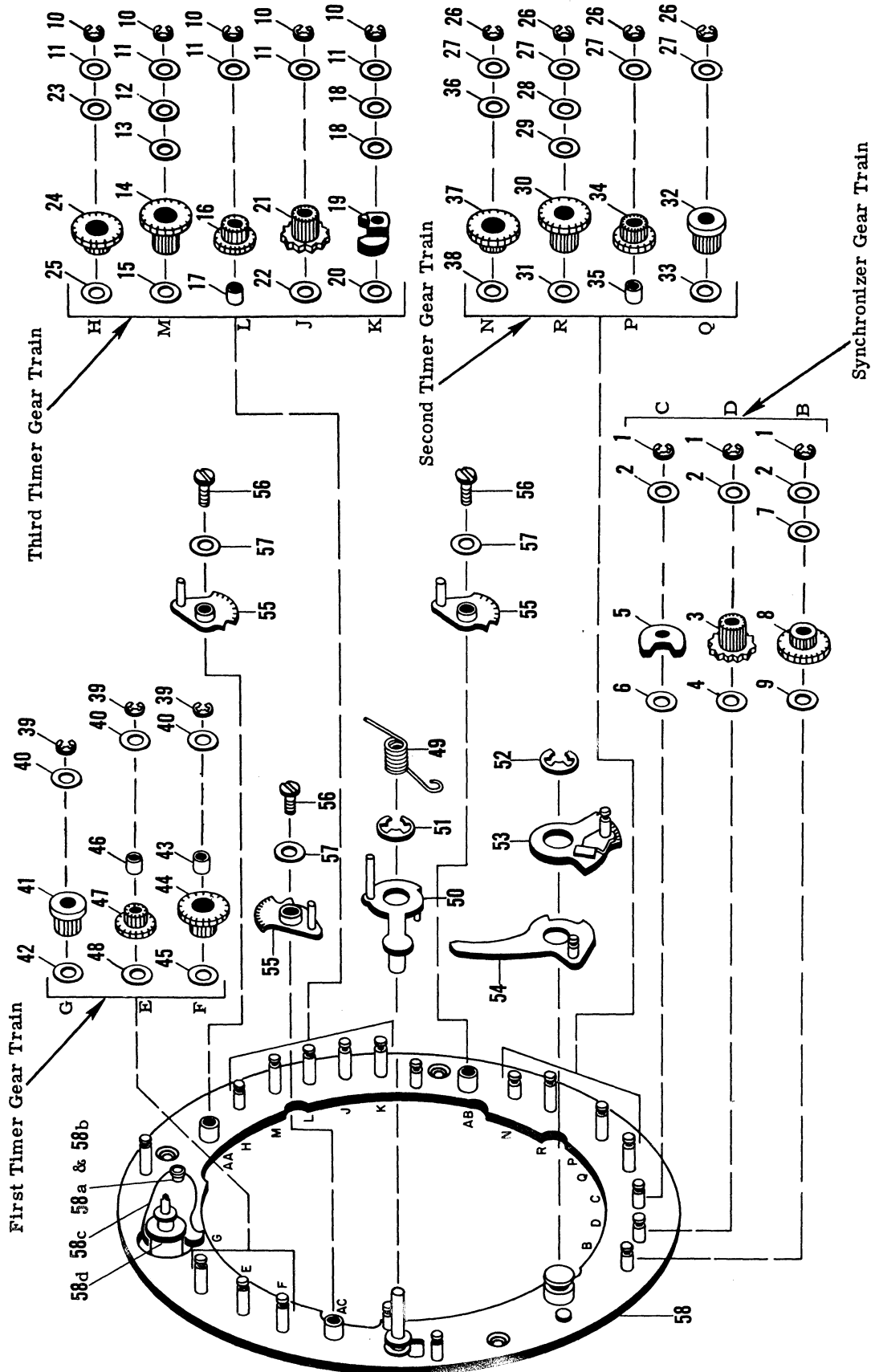

Figure 26. CONTROL PLATE COMPLETE

Figure and Index No.	Part Number	1	2	3	4	5	Nomenclature	Qty.	Code
26-	35378G1						Plate Complete - Control . . . . .	1	
							. Synchronizer Gear Train . . . . .	Ref.	
-1	251C3						. . Ring - Retaining . . . . .	3	
-2	35473-8						. . Washer - Flat, 0.125 x 0.053 x 0.005. . . . .	AR	
	35473-12						. . Washer - Flat, 0.125 x 0.053 x 0.008. . . . .	AR	
	35473-13						. . Washer - Flat, 0.125 x 0.053 x 0.002. . . . .	AR	
-3	35495G1						. . Starwheel Assembly. . . . .	1	
-4	35473-13						. . Washer - Flat (see index 2). . . . .	1	
-5	35403P2						. . Pallet - Starwheel (see page 28). . . . .	1	
	35403P5						. . Pallet - Starwheel (see page 28). . . . .	1	
	35403P6						. . Pallet - Starwheel (see page 28). . . . .	1	
	35402G1						. . Pallet Assembly - Starwheel (see page 28). . . . .	1	
-6	35473-13						. . Washer - Flat (see index 2). . . . .	1	
-7	35473-8						. . Washer - Flat (see index 2). . . . .	1	
-8	35494G1						. . Gear Assembly - Timing . . . . .	1	
-9	35473-8						. . Washer - Flat (see index 2). . . . .	1	
							. Third Timer Gear Train . . . . .	Ref.	
-10	251C3						. . Ring - Retaining . . . . .	5	
-11	35473-8						. . Washer - Flat (see index 2). . . . .	AR	
	35473-12						. . Washer - Flat (see index 2). . . . .	AR	
	35473-13						. . Washer - Flat (see index 2). . . . .	AR	
-12	35473-12						. . Washer - Flat (see index 2). . . . .	1	
-13	35473-8						. . Washer - Flat (see index 2). . . . .	1	
-14	35494G2						. . Gear Assembly - Timing . . . . .	1	
-15	35473-13						. . Washer - Flat (see index 2). . . . .	1	
-16	35933G1						. . Gear Assembly - Timing . . . . .	1	
-17	32090-18						. . Spacer (0.062 lg). . . . .	1	
-18	35473-12						. . Washer - Flat (see index 2). . . . .	2	
-19	35403P3						. . Pallet - Starwheel (see page 28) . . . . .	1	
	35403P4						. . Pallet - Starwheel (see page 28). . . . .	1	
	35403P7						. . Pallet - Starwheel (see page 28). . . . .	1	
-20	35473-8						. . Washer - Flat (see index 2). . . . .	1	
-21	35495G2						. . Starwheel Assembly. . . . .	1	
-22	35473-8						. . Washer - Flat (see index 2). . . . .	1	
-23	35473-12						. . Washer - Flat (see index 2). . . . .	1	
-24	35494G1						. . Gear Assembly - Timing . . . . .	1	
-25	38473-26						. . Washer - Flat, 0.085 x 0.053 x 0.002. . . . .	1	
							. Second Timer Gear Train. . . . .	Ref.	
-26	251C3						. . Ring - Retaining . . . . .	4	
-27	35473-8						. . Washer - Flat (see index 2). . . . .	AR	
	35433-12						. . Washer - Flat (see index 2). . . . .	AR	
	35473-13						. . Washer - Flat (see index 2). . . . .	AR	
-28	35473-12						. . Washer - Flat (see index 2). . . . .	1	
-29	35473-8						. . Washer - Flat (see index 2). . . . .	1	
-30	35494G2						. . Gear Assembly - Timing . . . . .	1	
-31	35473-13						. . Washer - Flat (see index 2). . . . .	1	
-32	35493G1						. . Weight Assembly (0.235 dia.) . . . . .	1	
	35493G3						. . Weight Assembly (0.225 dia.) . . . . .	1	
	35493G4						. . Weight Assembly (0.218 dia.) . . . . .	1	
-33	35473-13						. . Washer - Flat (see index 2). . . . .	1	
-34	35933G1						. . Gear Assembly - Timing . . . . .	1	
-35	32090-18						. . Spacer (see index 17). . . . .	1	
-36	35473-12						. . Washer - Flat . . . . .	1	
-37	35494G1						. . Gear Assembly - Timing . . . . .	1	
-38	38473-26						. . Washer - Flat (see index 25). . . . .	1	
							. First Timer Gear Train. . . . .	Ref.	
-39	251C3						. . Ring - Retaining . . . . .	3	
-40	35473-8						. . Washer - Flat (see index 2). . . . .	AR	
	35473-12						. . Washer - Flat (see index 2). . . . .	AR	
	35473-13						. . Washer - Flat (see index 2). . . . .	AR	
-41	35493G1						. . Weight Assembly (see index 32). . . . .	1	
	35493G3						. . Weight Assembly (see index 32). . . . .	1	
	35493G4						. . Weight Assembly (see index 32). . . . .	1	

Figure and Index No.	Part Number	1	2	3	4	5	Nomenclature	Qty.	Code
26-42	35473-13	.	.	.	.	.	Washer - Flat (see index 2)	1	
-43	32090-18	.	.	.	.	.	Spacer (see index 17)	1	
-44	35494G1	.	.	.	.	.	Gear Assembly - Timing	1	
-45	38473-26	.	.	.	.	.	Washer - Flat (see index 25)	1	
-46	32090-53	.	.	.	.	.	Spacer (0.043 lg)	1	
-47	35933G1	.	.	.	.	.	Gear Assembly - Timing	1	
-48	38473-28	.	.	.	.	.	Washer - Flat, 0.125 x 0.053 x 0.020	1	
-49	35379	.	.	.	.	.	Spring - Trip	1	
-50	35394G1	.	.	.	.	.	Lever Assembly - Trip	1	
Attaching Part									
-51	251-8	.	.	.	.	.	Ring - Retaining	1	
	---***---								
-52	251-8	.	.	.	.	.	Ring - Retaining	1	
-53	35384G1	.	.	.	.	.	Lever Assembly - Synchronizer	1	
-54	35391G1	.	.	.	.	.	Latch Assembly - Trip	1	
-55	35399G1	.	.	.	.	.	Dog Assembly - Timing	3	
Attaching Parts									
-56	35044P3	.	.	.	.	.	Screw - Machine	3	
-57	35380	.	.	.	.	.	Retainer - Timing Dog	3	
	---***---								
-58	35416G1	.	.	.	.	.	Plate Assembly - Control	1	
-58a	35413P1	.	.	.	.	.	Stud - Brake	1	
-58b	35973	.	.	.	.	.	Spool - Brake	1	
-58c	35390P1	.	.	.	.	.	Brake - Cam	1	
-58d	35421P1	.	.	.	.	.	Cam - Brake Pinion	1	

